

JVC

SERVICE MANUAL

COMPACT COMPONENT SYSTEM

FS-SD1000R

Area Suffix	
B	U.K.
E	Continental Europe
EN	Northern Europe

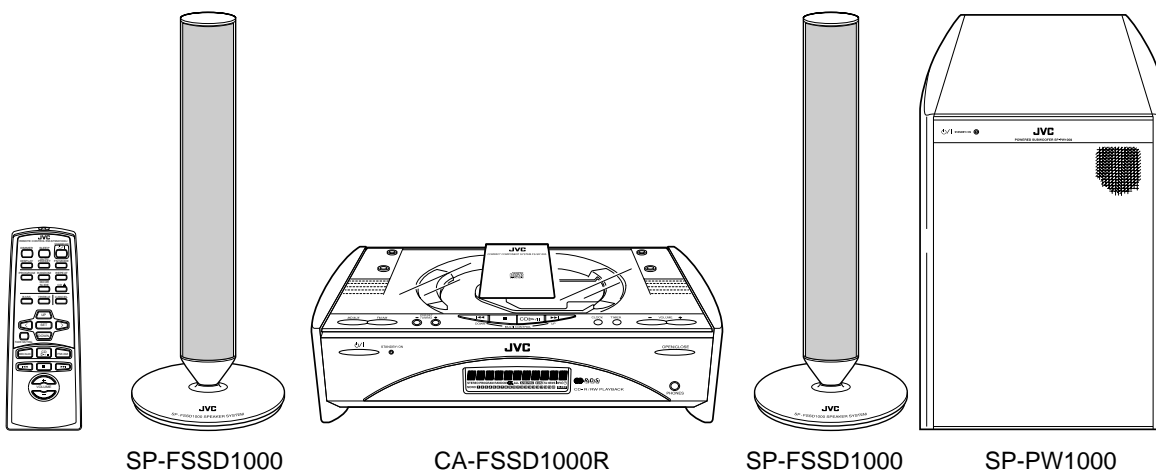

SP-FSSD1000

CA-FSSD1000R

SP-FSSD1000

SP-PW1000



Contents This model not have adjustment.

Safety Precautions	1-2	Flow of functional operation	
Important for laser products	1-4	unit TOC read	1-18
Preventing static electricity	1-5	Method of connecting	
Disassembly method	1-6	treatment device wire	1-19
Maintenance of laser pickup	1-17	Description of major ICs	1-20~32
Replacement of laser pickup	1-17		

Safety Precautions

1. This design of this product contains special hardware and many circuits and components specially for safety purposes. For continued protection, no changes should be made to the original design unless authorized in writing by the manufacturer. Replacement parts must be identical to those used in the original circuits. Services should be performed by qualified personnel only.
2. Alterations of the design or circuitry of the product should not be made. Any design alterations of the product should not be made. Any design alterations or additions will void the manufacturer's warranty and will further relieve the manufacture of responsibility for personal injury or property damage resulting therefrom.
3. Many electrical and mechanical parts in the products have special safety-related characteristics. These characteristics are often not evident from visual inspection nor can the protection afforded by them necessarily be obtained by using replacement components rated for higher voltage, wattage, etc. Replacement parts which have these special safety characteristics are identified in the Parts List of Service Manual. Electrical components having such features are identified by shading on the schematics and by (\triangle) on the Parts List in the Service Manual. The use of a substitute replacement which does not have the same safety characteristics as the recommended replacement parts shown in the Parts List of Service Manual may create shock, fire, or other hazards.
4. The leads in the products are routed and dressed with ties, clamps, tubings, barriers and the like to be separated from live parts, high temperature parts, moving parts and/or sharp edges for the prevention of electric shock and fire hazard. When service is required, the original lead routing and dress should be observed, and it should be confirmed that they have been returned to normal, after re-assembling.

5. Leakage current check (Electrical shock hazard testing)

After re-assembling the product, always perform an isolation check on the exposed metal parts of the product (antenna terminals, knobs, metal cabinet, screw heads, headphone jack, control shafts, etc.) to be sure the product is safe to operate without danger of electrical shock.

Do not use a line isolation transformer during this check.

- Plug the AC line cord directly into the AC outlet. Using a "Leakage Current Tester", measure the leakage current from each exposed metal parts of the cabinet, particularly any exposed metal part having a return path to the chassis, to a known good earth ground. Any leakage current must not exceed 0.5mA AC (r.m.s.).

- Alternate check method

Plug the AC line cord directly into the AC outlet. Use an AC voltmeter having, 1,000 ohms per volt or more sensitivity in the following manner. Connect a 1,500 Ω 10W resistor paralleled by a 0.15 μ F AC-type capacitor between an exposed metal part and a known good earth ground. Measure the AC voltage across the resistor with the AC voltmeter.

Move the resistor connection to each exposed metal part, particularly any exposed metal part having a return path to the chassis, and measure the AC voltage across the resistor. Now, reverse the plug in the AC outlet and repeat each measurement. Any voltage measured must not exceed 0.75 V AC (r.m.s.). This corresponds to 0.5 mA AC (r.m.s.).

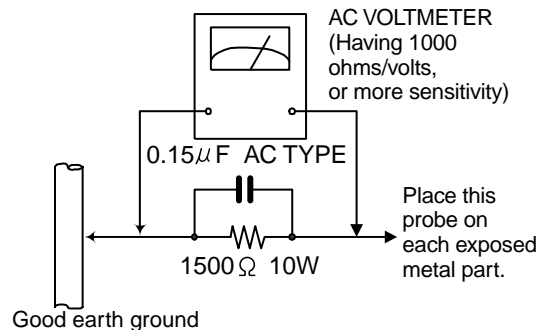

Warning

1. This equipment has been designed and manufactured to meet international safety standards.
2. It is the legal responsibility of the repairer to ensure that these safety standards are maintained.
3. Repairs must be made in accordance with the relevant safety standards.
4. It is essential that safety critical components are replaced by approved parts.
5. If mains voltage selector is provided, check setting for local voltage.

CAUTION

Burrs formed during molding may be left over on some parts of the chassis. Therefore, pay attention to such burrs in the case of performing repair of this system.

In regard with component parts appearing on the silk-screen printed side (parts side) of the PWB diagrams, the parts that are printed over with black such as the resistor (■), diode (▣) and ICP (●) or identified by the " \triangle " mark nearby are critical for safety.

When replacing them, be sure to use the parts of the same type and rating as specified by the manufacturer. (Except the JC version)

Safety precautions (U.K only)

1. This design of this product contains special hardware and many circuits and components specially for safety purposes. For continued protection, no changes should be made to the original design unless authorized in writing by the manufacturer. Replacement parts must be identical to those used in the original circuits.
2. Any unauthorised design alterations or additions will void the manufacturer's guarantee ; furthermore the manufacturer cannot accept responsibility for personal injury or property damage resulting therefrom.
3. Essential safety critical components are identified by () on the Parts List and by shading on the schematics, and must never be replaced by parts other than those listed in the manual. Please note however that many electrical and mechanical parts in the product have special safety related characteristics. These characteristics are often not evident from visual inspection. Parts other than specified by the manufacturer may not have the same safety characteristics as the recommended replacement parts shown in the Parts List of the Service Manual and may create shock, fire, or other hazards.
4. The leads in the products are routed and dressed with ties, clamps, tubings, barriers and the like to be separated from live parts, high temperature parts, moving parts and/or sharp edges for the prevention of electric shock and fire hazard. When service is required, the original lead routing and dress should be observed, and it should be confirmed that they have been returned to normal, after re-assembling.

Warning

1. Service should be performed by qualified personnel only.
2. This equipment has been designed and manufactured to meet international safety standards.
3. It is the legal responsibility of the repairer to ensure that these safety standards are maintained.
4. Repairs must be made in accordance with the relevant safety standards.
5. It is essential that safety critical components are replaced by approved parts.
6. If mains voltage selector is provided, check setting for local voltage.

 **CAUTION** Burrs formed during molding may be left over on some parts of the chassis. Therefore, pay attention to such burrs in the case of performing repair of this system.

Important for laser products

1.CLASS 1 LASER PRODUCT

2.DANGER : Invisible laser radiation when open and inter lock failed or defeated. Avoid direct exposure to beam.

3.CAUTION : There are no serviceable parts inside the Laser Unit. Do not disassemble the Laser Unit. Replace the complete Laser Unit if it malfunctions.

4.CAUTION : The compact disc player uses invisible laser radiation and is equipped with safety switches which prevent emission of radiation when the drawer is open and the safety interlocks have failed or are defeated. It is dangerous to defeat the safety switches.

5.CAUTION : If safety switches malfunction, the laser is able to function.

6.CAUTION : Use of controls, adjustments or performance of procedures other than those specified herein may result in hazardous radiation exposure.

⚠ CAUTION Please use enough caution not to see the beam directly or touch it in case of an adjustment or operation check.

WARNING : Osynlig laserstrålning är denna del är öppnad och spärren är urkopplad. Betrakta ej strålen.

VARO : Avattaessa ja suojalukitus ohitettaessa olet alltiina näkymättömälle lasersäteilylle.Älä katso säteeseen.

ADVARSEL : Usynlig laserstrålning ved åbning , når sikkerhedsafbrydere er ude af funktion. Undgå udsættelse for stråling.

ADVARSEL : Usynlig laserstrålning ved åbning,når sikkerhetsbryteren er avslott. unngå utsettelse for stråling.

REPRODUCTION AND POSITION OF LABELS

WARNING LABEL

**CLASS 1
LASER PRODUCT**

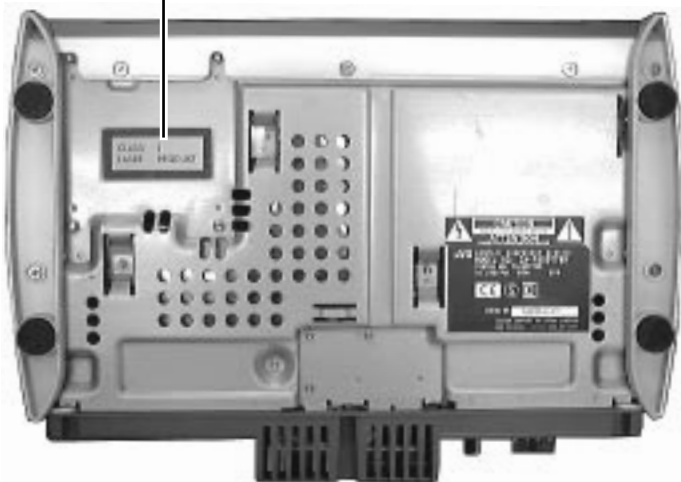

DANGER : Invisible laser radiation when open and interlock or defeated.
AVOID DIRECT EXPOSURE TO BEAM (e)

WARNING : Osynlig laserstrålning är denna del är öppnad och spärren är urkopplad. Betrakta ej strålen. (s)

VARO : Avattaessa ja suojalukitus ohitettaessa olet alltiina näkymättömälle lasersäteilylle.Älä katso säteeseen. (d)

ADVARSEL :Usynlig laserstrålning ved åbning , når sikkerhedsafbrydere er ude af funktion. Undgå udsættelse for stråling. (f)

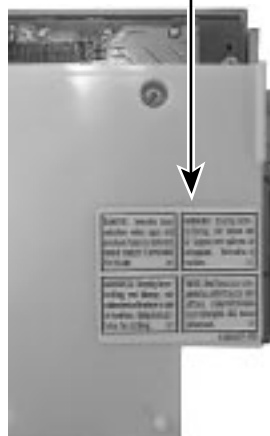

Preventing static electricity

1. Grounding to prevent damage by static electricity

Electrostatic discharge (ESD), which occurs when static electricity stored in the body, fabric, etc. is discharged, can destroy the laser diode in the traverse unit (optical pickup). Take care to prevent this when performing repairs.

2. About the earth processing for the destruction prevention by static electricity

Static electricity in the work area can destroy the optical pickup (laser diode) in devices such as CD players. Be careful to use proper grounding in the area where repairs are being performed.

2-1 Ground the workbench

Ground the workbench by laying conductive material (such as a conductive sheet) or an iron plate over it before placing the traverse unit (optical pickup) on it.

2-2 Ground yourself

Use an anti-static wrist strap to release any static electricity built up in your body.

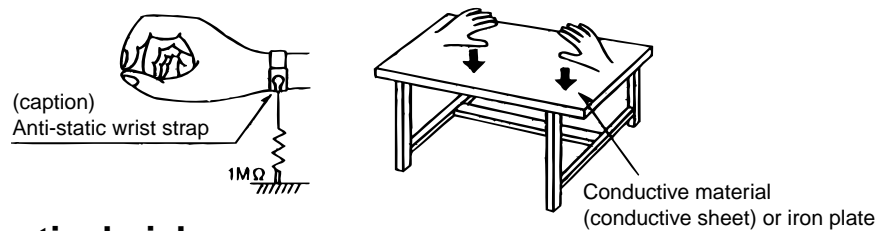

3. Handling the optical pickup

1. In order to maintain quality during transport and before installation, both sides of the laser diode on the replacement optical pickup are shorted. After replacement, return the shorted parts to their original condition. (Refer to the text.)
2. Do not use a tester to check the condition of the laser diode in the optical pickup. The tester's internal power source can easily destroy the laser diode.

4. Handling the traverse unit (optical pickup)

1. Do not subject the traverse unit (optical pickup) to strong shocks, as it is a sensitive, complex unit.
2. Cut off the shorted part of the flexible cable using nippers, etc. after replacing the optical pickup. For specific details, refer to the replacement procedure in the text. Remove the anti-static pin when replacing the traverse unit. Be careful not to take too long a time when attaching it to the connector.
3. Handle the flexible cable carefully as it may break when subjected to strong force.
4. It is not possible to adjust the semi-fixed resistor that adjusts the laser power. Do not turn it

Attention when traverse unit is decomposed

***Please refer to "Disassembly method" in the text for pick-up and how to detach the substrate.**

1. Solder is put up before the card wire is removed from connector on the CD substrate as shown in Figure.
(When the wire is removed without putting up solder, the CD pick-up assembly might destroy.)
2. Please remove solder after connecting the card wire with when you install picking up in the substrate.

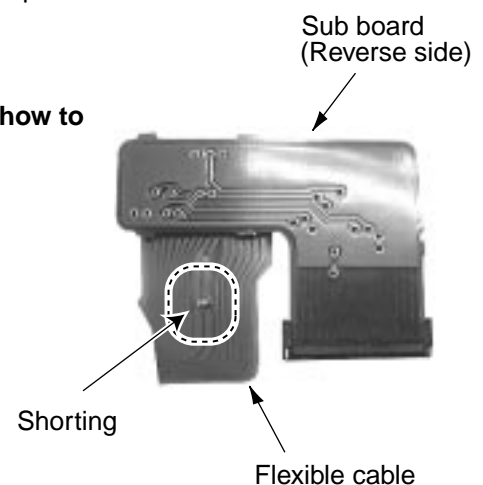

Disassembly method

<Main body>

■Removing the CD door (See Fig.1)

1. Remove the four screws **A** attaching the CD door on the upper side of the body.

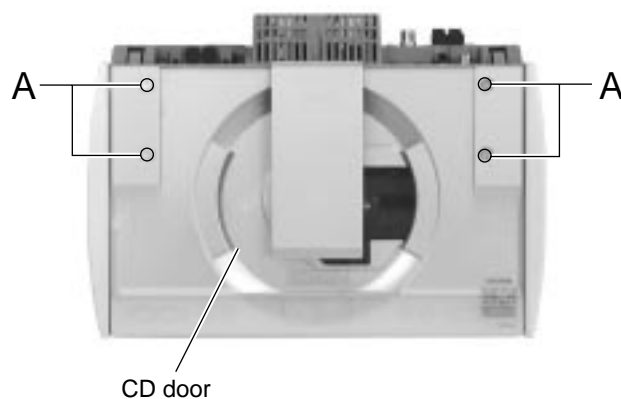

Fig.1

■Removing the rear cover (See Fig.2)

- Prior to performing the following procedure, remove the CD door.
1. Remove the ten screws **B** and the five screws **C** attaching the rear cover on the back of the body.

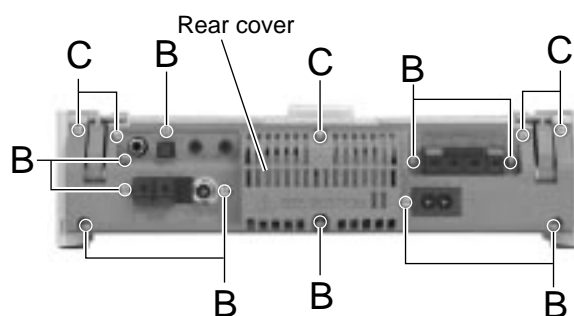

Fig.2

■Removing the right and left covers (See Fig.3)

- Prior to performing the following procedure, remove the CD door, the rear cover.
1. Remove the four screws **D** attaching the side covers on the bottom of the body.
 2. Move the left cover backward and remove outward. Also remove the right cover in the same way.

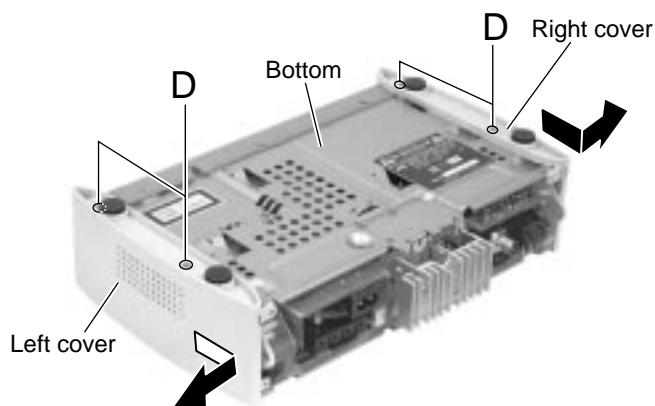
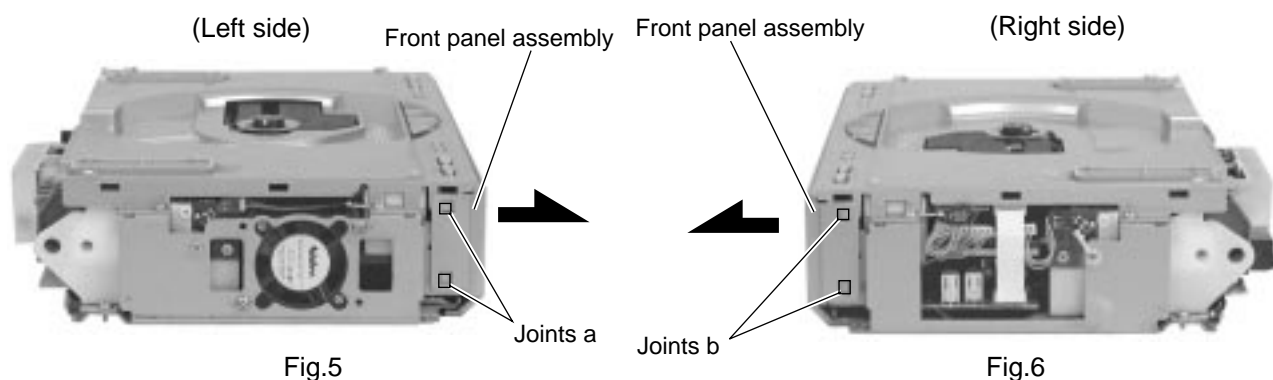
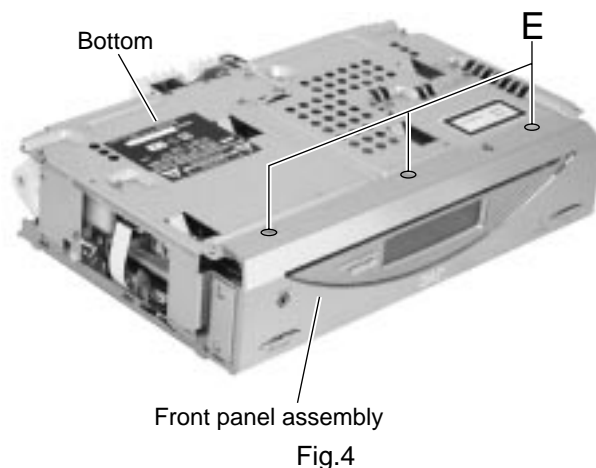

Fig.3

■ Removing the front panel assembly (See Fig.4 to 6)

• Prior to performing the following procedure, remove the CD door, the rear cover and the side covers.

1. Remove the three screws **E** on the bottom of the body.
2. Release two joints **a** and two joints **b** on both sides of the body using a screwdriver and remove the front panel assembly toward the front.



■ Removing the CD mechanism base assembly (See Fig.7 to 14)

• Prior to performing the following procedure, remove the CD door, the rear cover, the side covers and the front panel assembly.

1. Disconnect the card wire from connector CN104 and CN105 of the main board in the front part of the body. Disconnect the card wire from CN101 of the main board on the right side, and the wire from CN705 and CN708 of the CD mechanism base assembly respectively.
2. Remove the four screws **F** attaching the CD mechanism base assembly on the upper side of the body. Remove the screw **I** attaching the earth terminal on the right side.

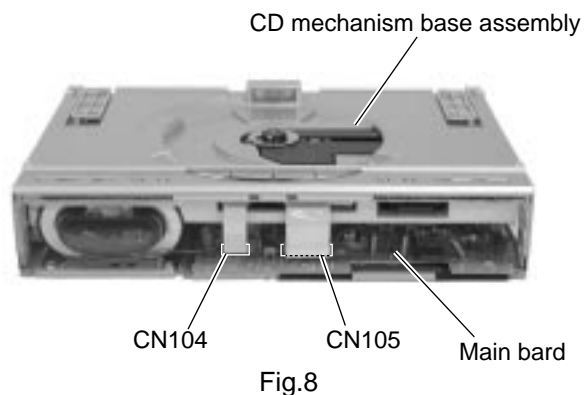
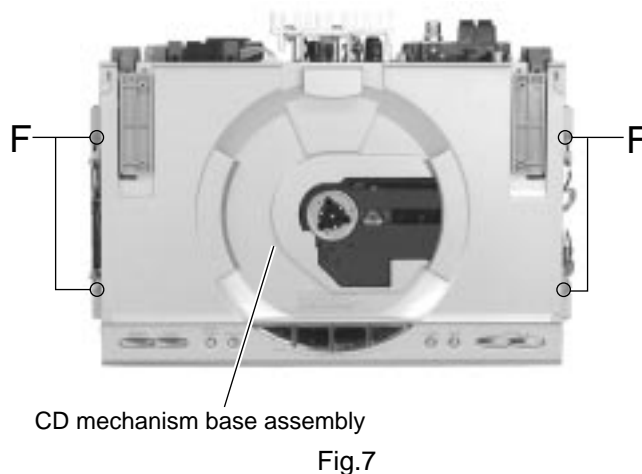

3. Remove the screw **G** attaching the power amplifier board on the back of the body. Disconnect the wire from connector CN301 and pull the power amplifier board fully outward.
4. Raise the right and left door arms by turning the gear **a** in the rear of the power amplifier board.
5. After the CD mechanism base assembly is detached from the door arms, pull the CD mechanism base assembly toward the front and disconnect the wire from connector CN804 on the left side of the door arm board.
6. Pull out the CD mechanism base assembly toward the front.

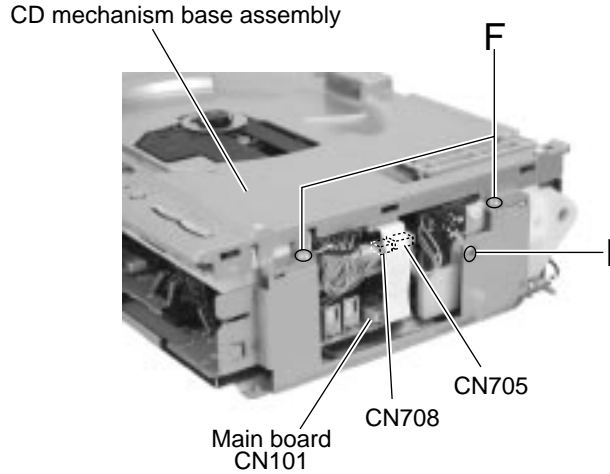

Fig.9

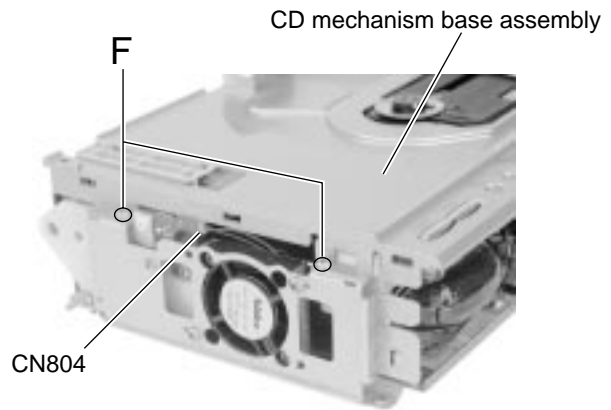

Fig.10

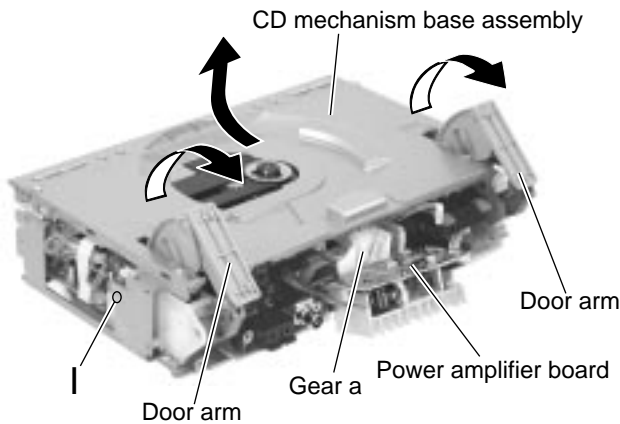

Fig.12

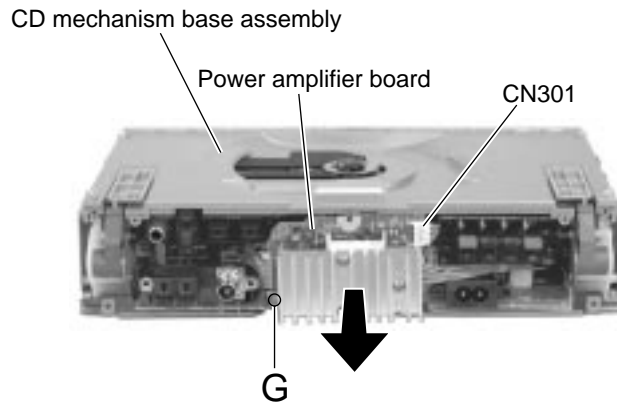

Fig.11

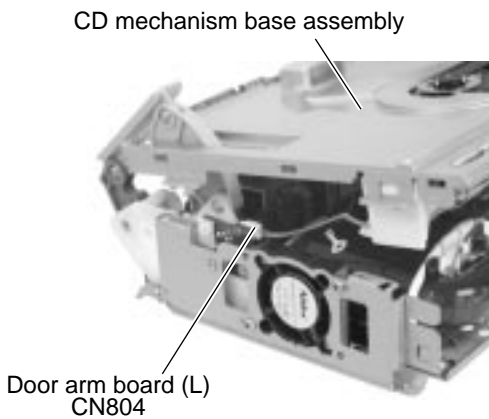

Fig.14

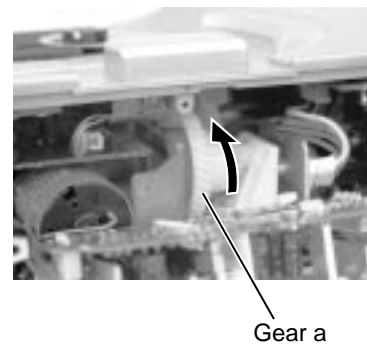

Fig.13

■Removing the door arm assembly / the door arm board (R) and (L)
(See Fig.15 to 20)

• Prior to performing the following procedure, remove the rear cover, the side covers, the front panel assembly and the CD mechanism base assembly.

1. In case that the upper parts of the door arms attached to the CD door are not level, let down them to the level position by turning the gear **a** in the direction of the arrow.

ATTENTION: When the door arms incline, the door arm assembly and the door arm board (R) and (L) may not be removed.

2. Remove the four screws **H** on the upper side and the one screw **I** on the left side of the body.
3. Remove the four screws **J** attaching the door arm board (L) and (R) on both sides of the door arm assembly.

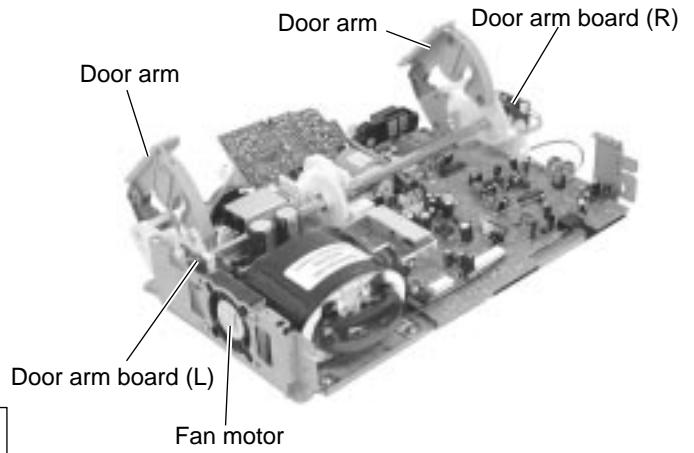

Fig.15

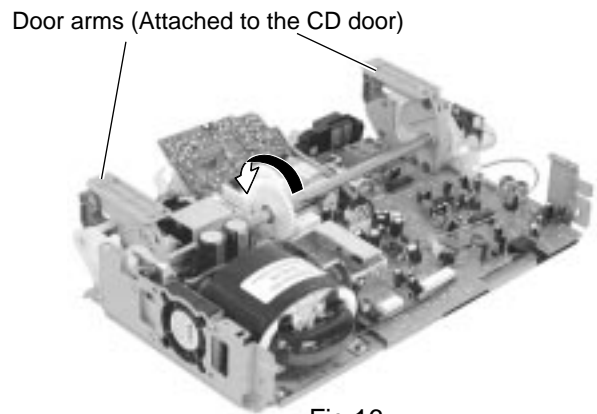

Fig.16

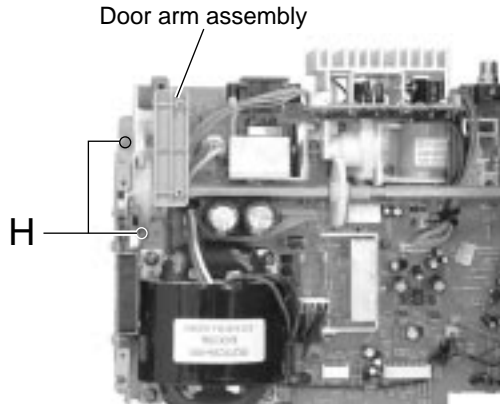

Fig.17

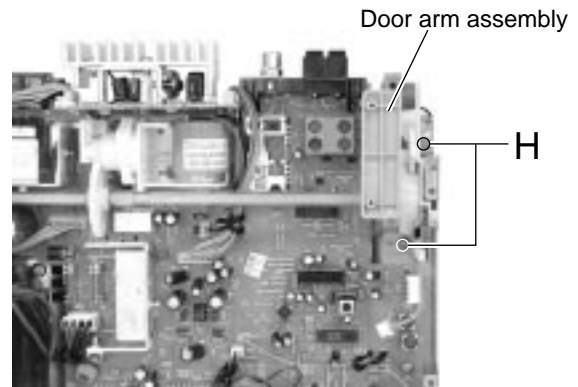

Fig.18

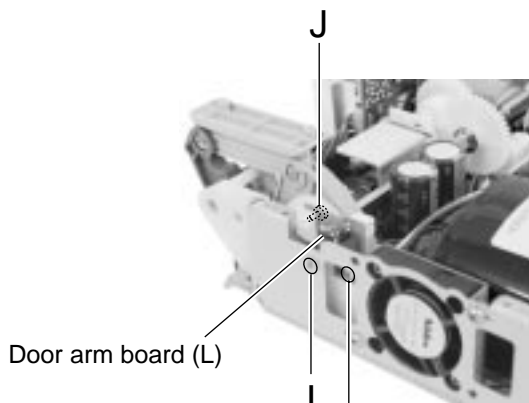

Fig.19

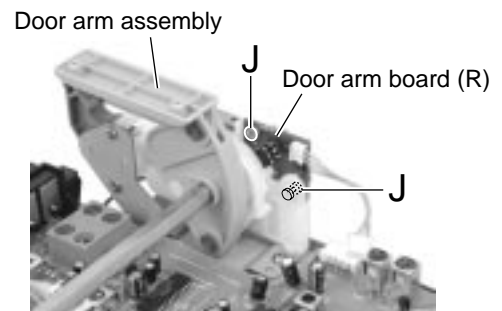

Fig.20

**■Removing the power amplifier board
(See Fig.21 and 22)**

• Prior to performing the following procedure, remove the CD mechanism base assembly.

1. Disconnect the wires from connector CN102 and CN193 on the main board and release them from the cord stopper respectively.
2. Remove the two screws **K** and the two screws **L** attaching the heat sink and the power amplifier board.

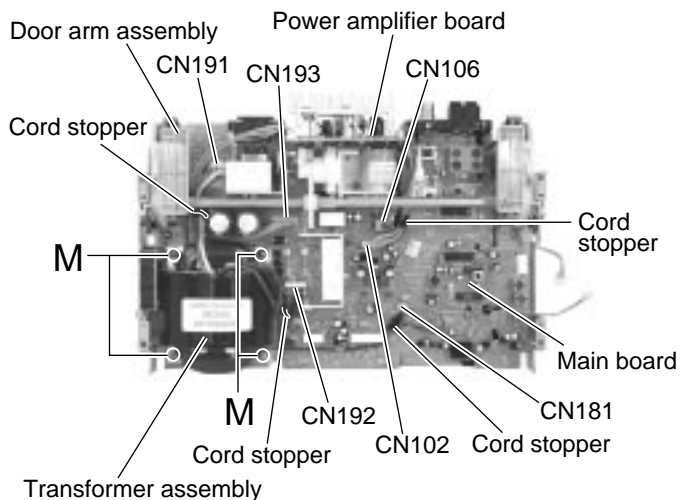

Fig.21

**■Removing the transformer assembly
(See Fig.21)**

• Prior to performing the following procedure, remove the CD mechanism base assembly.

1. Disconnect the wires from connector CN191 and CN192 on the main board and release them from the cord stopper respectively.
2. Remove the four screws **M** attaching the transformer assembly.

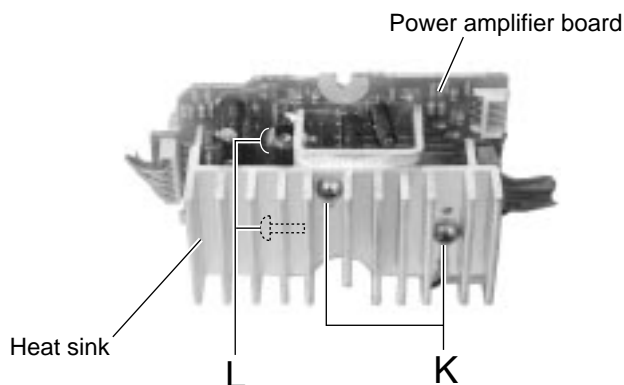

Fig.22

**■Removing the gear motor assembly
(See Fig.23 and 24)**

• Prior to performing the following procedure, remove the CD mechanism base assembly and the door arm assembly.

1. Disconnect the wires from connector CN106 on the main board and release it from the cord stopper.
2. Remove the three screws **N** attaching the gear motor assembly. Remove the gear motor assembly with the gear motor stopper.
3. Remove the belt from the gear motor assembly.
4. Remove the two screws **O** from the gear motor assembly.

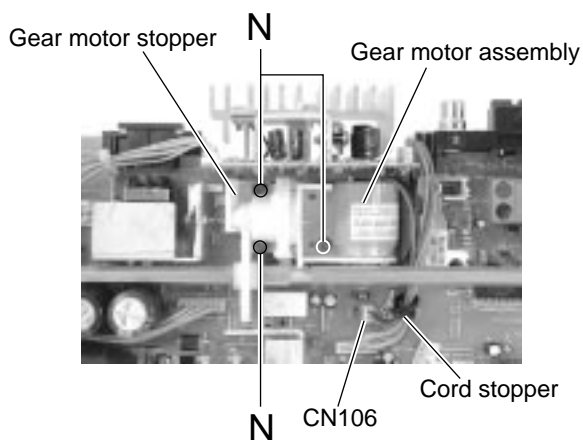

Fig.23

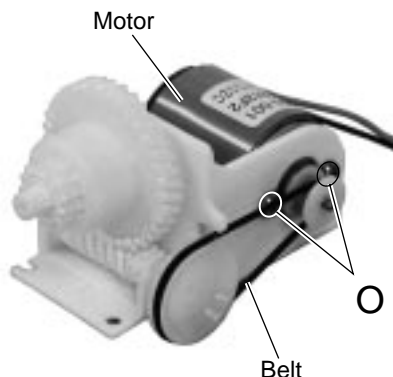

Fig.24

**■Removing the fan motor assembly
(See Fig.25 and 26)**

• Prior to performing the following procedure, remove the CD mechanism base assembly.

1. Disconnect the wires from connector CN181 on the main board.
2. Remove the two screws **P** on the left side of the body. Move the fan motor assembly upward to remove it from the base chassis.
3. Remove the two screws **Q** and the fan motor from the fan bracket.

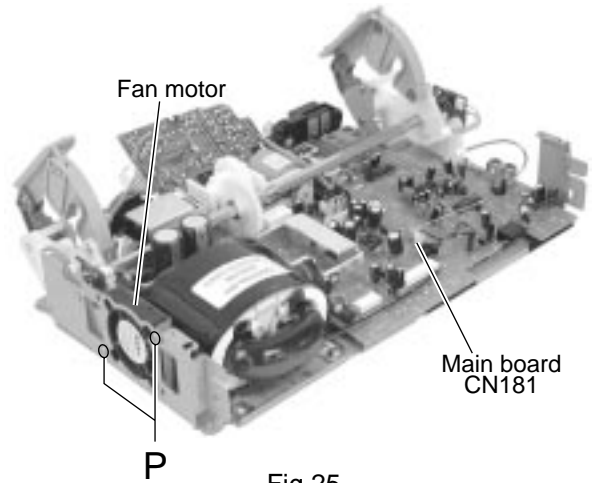

Fig.25

■Removing the main board (See Fig.27)

• Prior to performing the following procedure, remove the CD mechanism base assembly and the door arm assembly.

• To facilitate operation process, remove the gear motor assembly before performing the following procedure.

1. Disconnect the wires from connector CN102, CN106, CN191, CN192, CN193 and CN181 on the main board.
2. Remove the five screws **R** attaching the main board with the cord stopper.

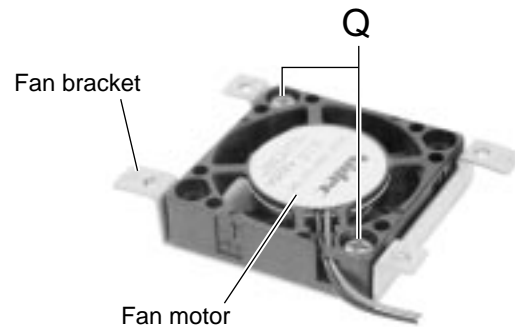

Fig.26

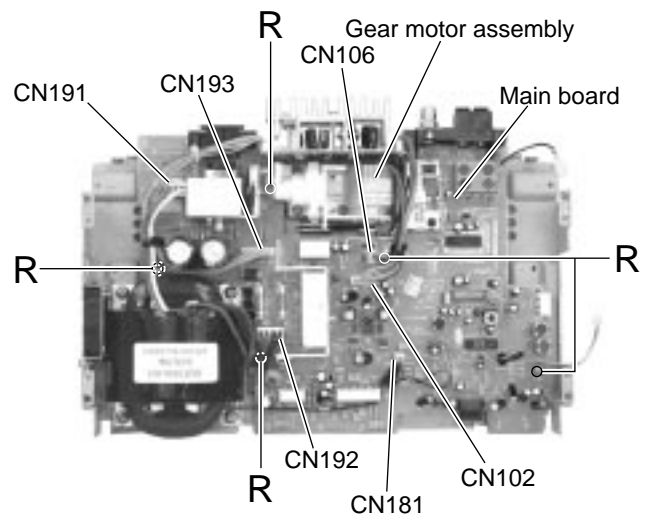

Fig.27

<Front panel assembly>

**■Removing the front panel board
(See Fig.28)**

• Prior to performing the following procedure, remove the front panel assembly.

1. Remove the seven screws **S** attaching the front panel board inside the front panel assembly.

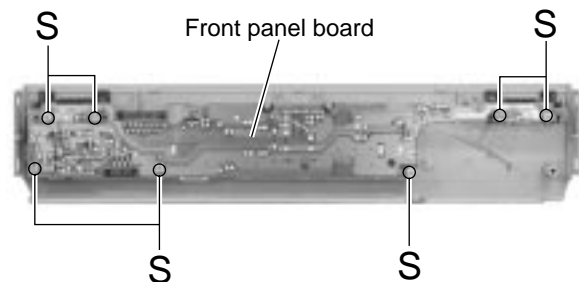

Fig.28

<CD mechanism base assembly>

- Prior to performing the following procedure, remove the CD mechanism base assembly.
- Refer to "Dismantling and assembling the CD mechanism assembly" on page 1-5 for the treatment of optical pickup.

■Removing the speaker terminal board (See Fig.29)

1. Remove the screw **T** attaching the speaker terminal board on the underside of the CD mechanism base assembly.

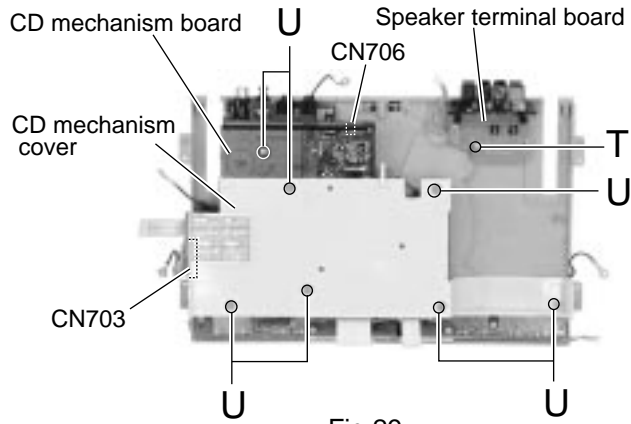

Fig.29

■Removing the CD mechanism board / CD mechanism assembly (See Fig.29 to 34)

1. Turn over the CD mechanism base assembly and disconnect the wires from connector CN703 and CN706 on the CD mechanism board.
2. Remove the seven screws **U** attaching the CD mechanism cover and the CD mechanism board.
3. Turn back the CD mechanism assembly and detach the CD mechanism cover while pulling the CD mechanism assembly outward to release the two joint tabs marked **c**.

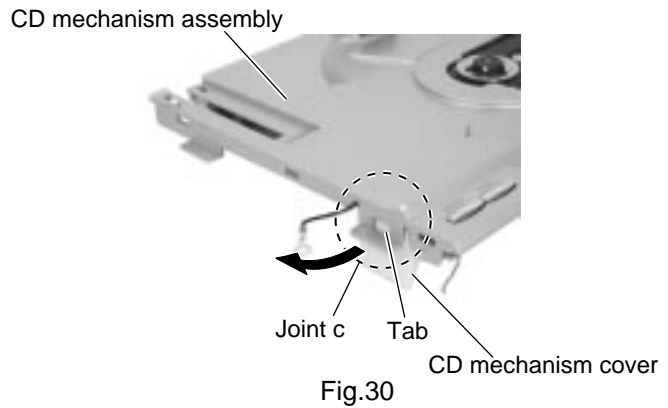

Fig.30

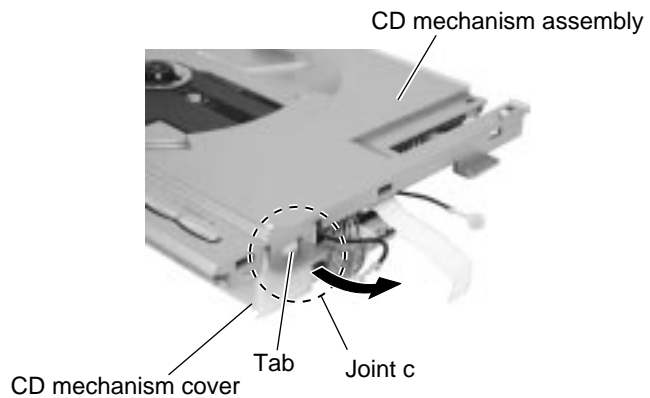

Fig.31

4. Solder the short circuit land on the sub board.

5. Disconnect the wire from connector CN605 on the main board.

Disconnect the sub board from connector CN603 on the main board while peeling off the adhesive tape on the underside of the sub board.

6. Remove the CD mechanism assembly from the three shafts of the CD mechanism cover.

ATTENTION: When reassembling, confirm that the cushion of the CD mechanism assembly is reattached to the three shafts.

7. Remove the CD mechanism board from the CD mechanism cover.

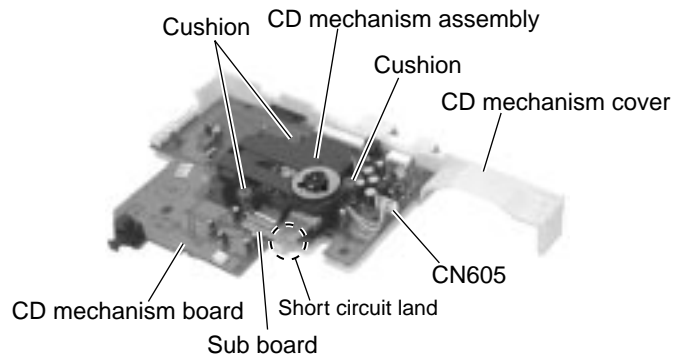

Fig.32

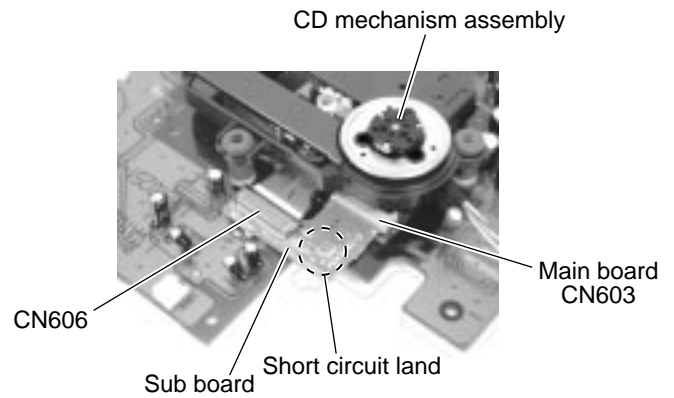

Fig.33

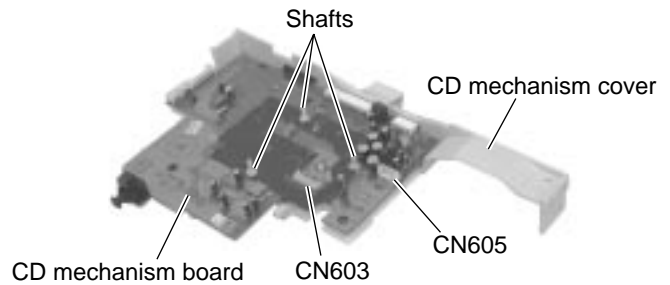

Fig.34

■Removing the jack board (See Fig.35)

- Prior to performing following procedure, remove the CD mechanism board.
1. Disconnect the wire from connector CN502 on the jack board.
 2. Remove the two screws **V** attaching the jack board.

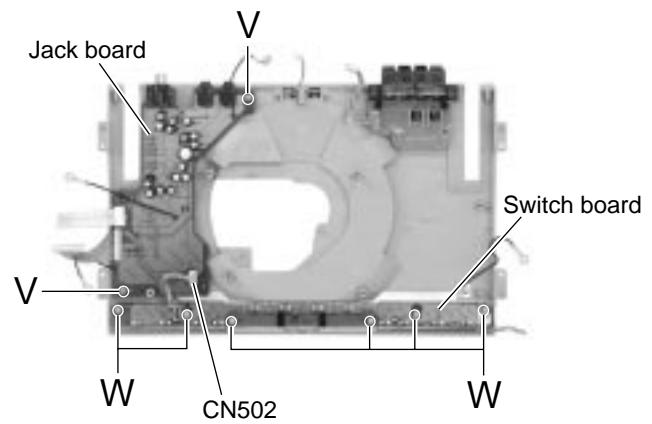

Fig.35

■Removing the switch board (See Fig.35)

- Prior to performing following procedure, remove the CD mechanism board.
1. Disconnect the wire from connector CN502 on the jack board.
 2. Remove the six screws **W** attaching the switch board.

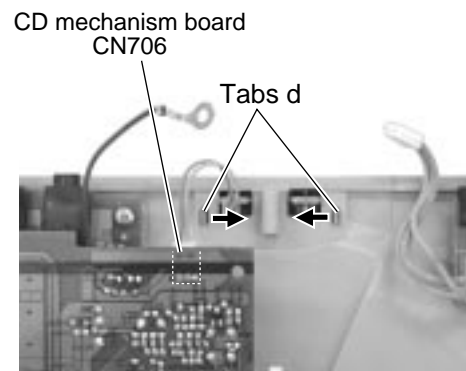

Fig.36

■Removing the LED board (See Fig.36 and 37)

1. Disconnect the harness from connector CN706 on the CD mechanism board on the underside of the CD mechanism base assembly.
2. Push inward the two tabs **d** attaching the LED board case and release them.
3. Pull out the LED board from the LED board case.

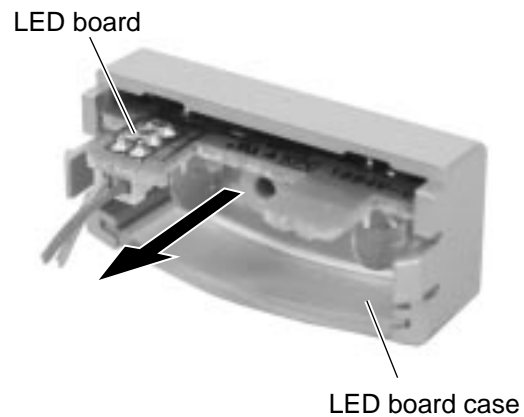

Fig.37

Power woofer section

<Main body>

■ Removing the amplifier assembly (See Fig.1)

1. Remove the eleven screws **A** attaching the amplifier assembly on the back of the body.
2. Disconnect each relay harness connected to the speaker and the LED indicator board.

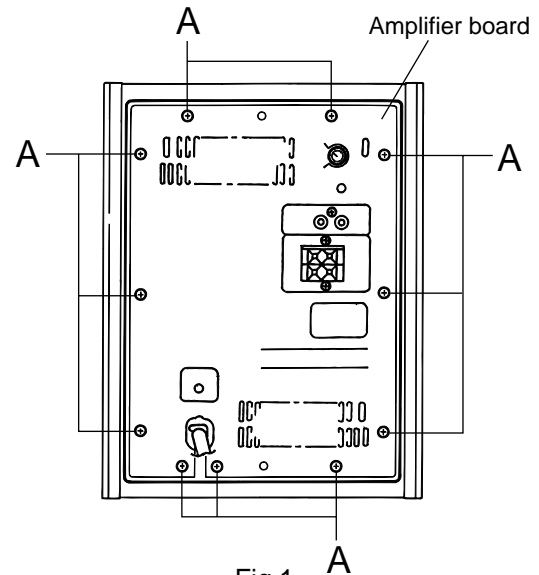

Fig.1

<Amplifier>

■ Removing the cover (See Fig.2)

1. Pull out the volume knob from the amplifier.
2. Remove the three screws **B** on the amplifier.

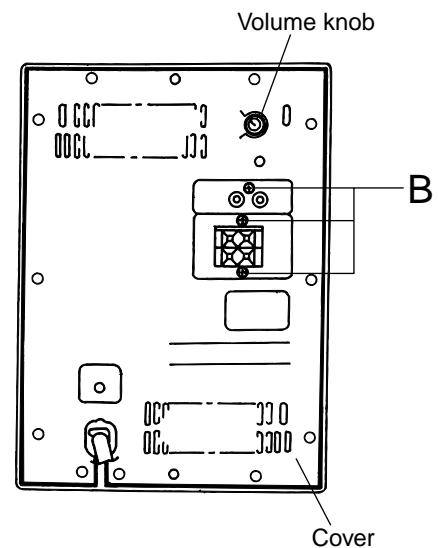

Fig.2

■ Removing the Input amplifier / filter board assembly (See Fig.3)

1. Cut off the band under the input amplifier / filter board assembly.
2. Disconnect the harness from connector CN251.
3. Remove the two screws **C** attaching the input amplifier / filter board assembly. Pull and disconnect connector CN211 from the body.

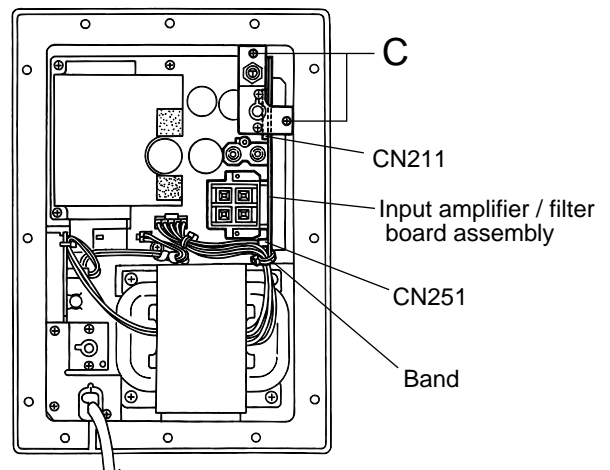

Fig.3

**■ Removing the amplifier board assembly
(See Fig.4 and 5)**

• Prior to performing procedure, remove the input amplifier / filter board assembly.

1. Disconnect the harness from connector CN291 and CN281 on the amplifier board assembly.
2. Remove the six screws **D** attaching the amplifier board assembly.
3. Remove the two screws **E** attaching the heat sink 1 and the two screws **F** attaching the heat sink 2 respectively.

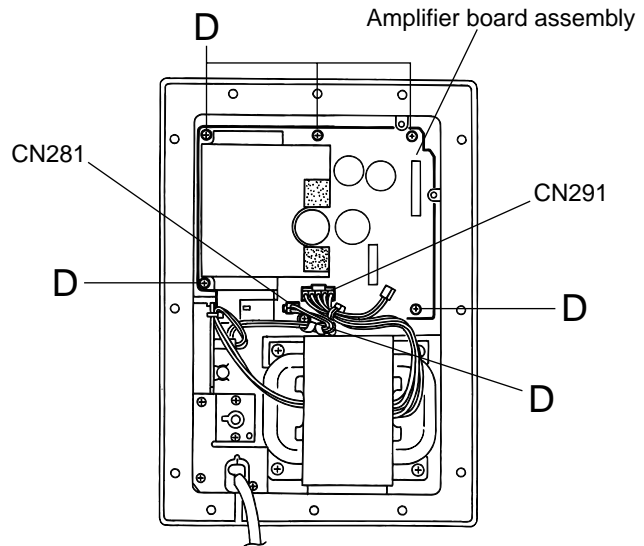

Fig.4

**■ Removing the transformer assembly
(See Fig.6)**

1. Cut off the three bands fastening the harnesses extending from the transformer assembly.
2. Disconnect the harness from connector CN291 on the amplifier board assembly and from CN299 on the power board assembly.
3. Remove the four screws **G** attaching the transformer assembly.

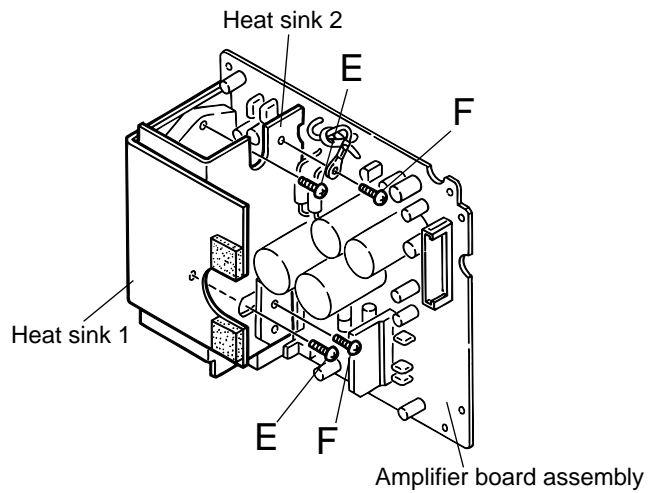

Fig.5

**■ Removing the power board assembly
(See Fig.7)**

1. Disconnect the harness from connector CN299 on the power board assembly and cut off the band.
2. Remove the three screws **H** assembly.
3. Remove the cord stopper.

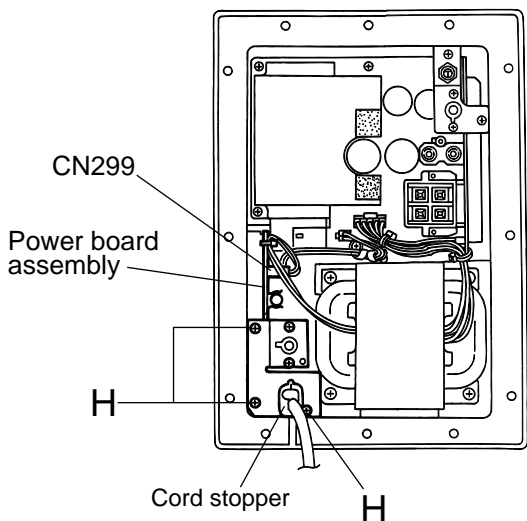

Fig.7

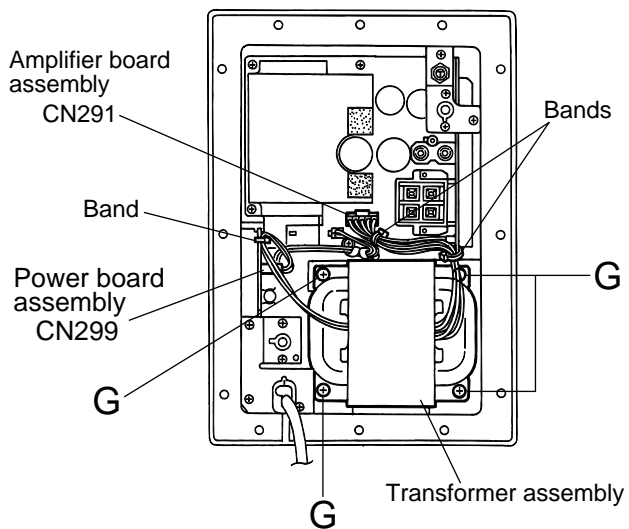
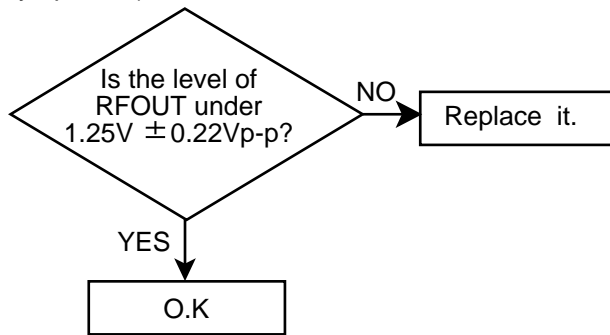

Fig.6

Maintenance of laser pickup

- (1) Cleaning the pick up lens
Before you replace the pick up, please try to clean the lens with a alcohol soaked cotton swab.
- (2) Life of the laser diode
When the life of the laser diode has expired, the following symptoms will appear.
 1. The level of RF output (EFM output:amplitude of eye pattern) will below.



Replacement of laser pickup

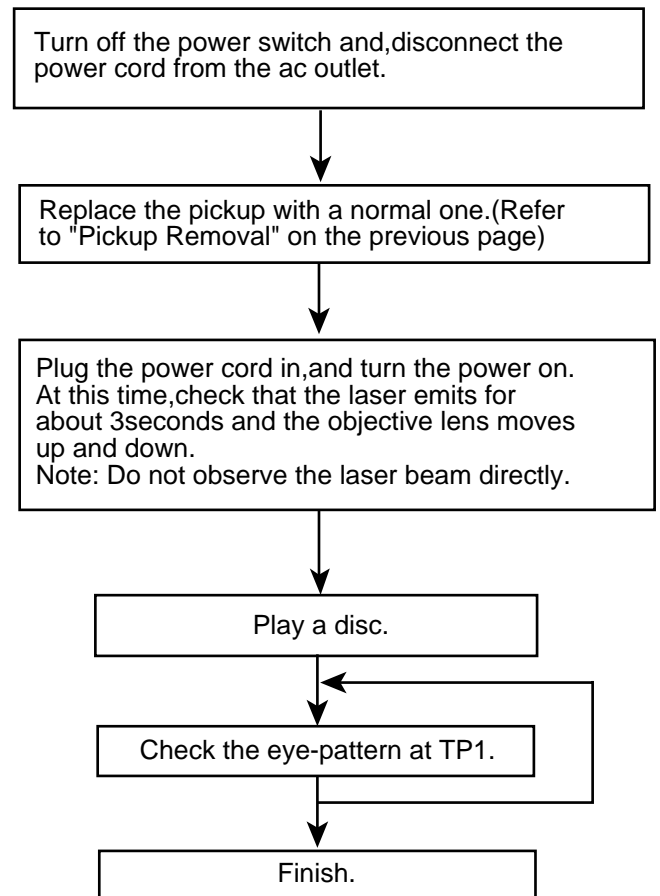

- (3) Semi-fixed resistor on the APC PC board The semi-fixed resistor on the APC printed circuit board which is attached to the pickup is used to adjust the laser power. Since this adjustment should be performed to match the characteristics of the whole optical block, do not touch the semi-fixed resistor.
If the laser power is lower than the specified value, the laser diode is almost worn out, and the laser pickup should be replaced.
If the semi-fixed resistor is adjusted while the pickup is functioning normally, the laser pickup may be damaged due to excessive current.

Flow of functional operation until TOC read

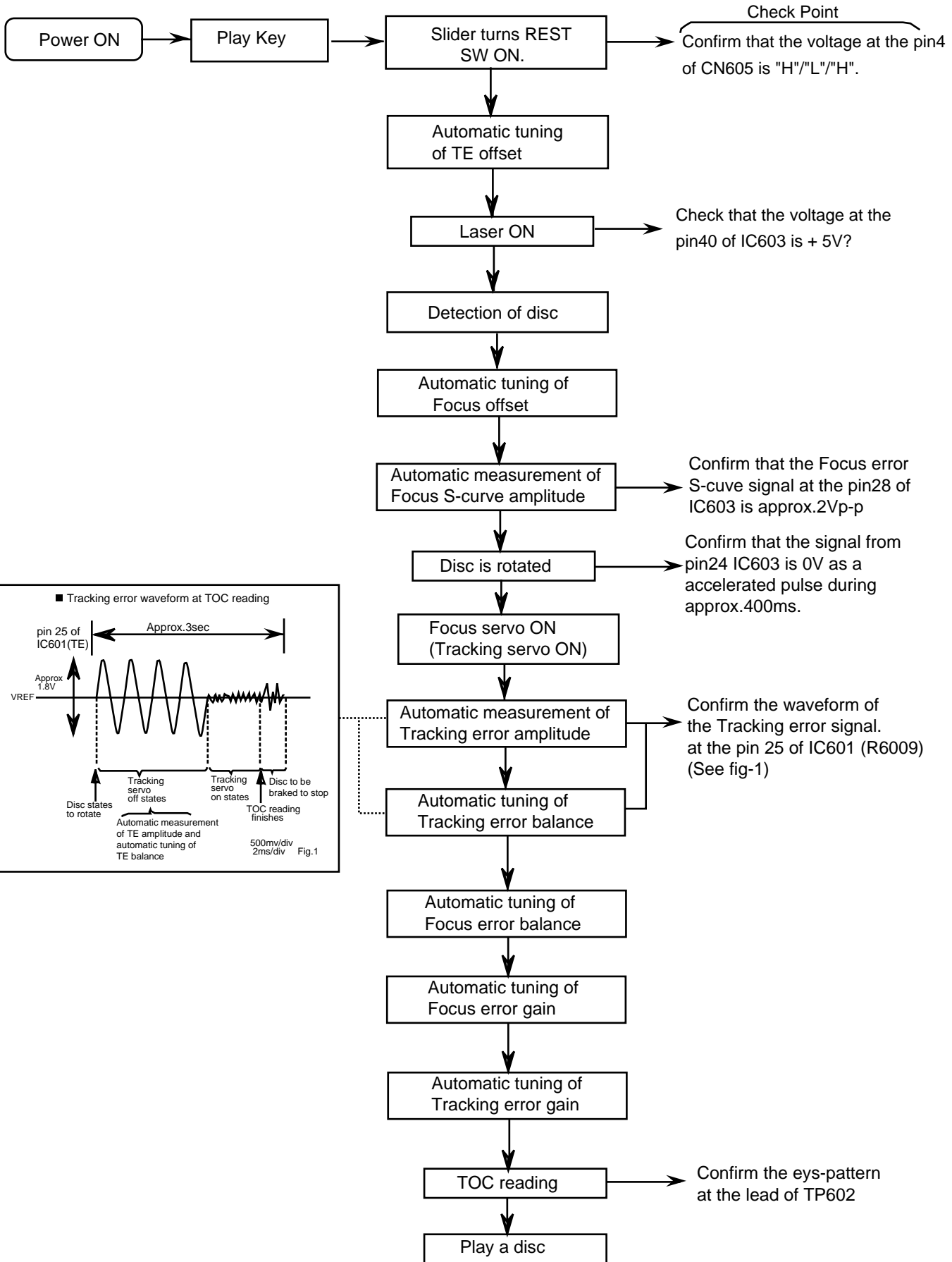

Method of connecting treatment device wire

First short-circuit the pickup circuit before removing the pickup. Then carry out the replacement. Refer to "Disassembling and assembling the traverse unit".

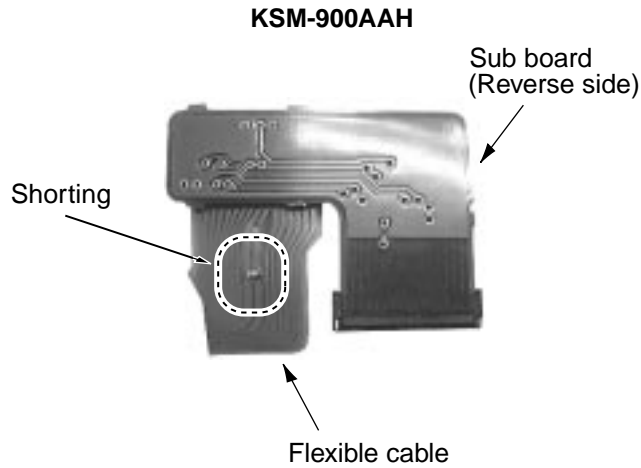

When the KSM-900AAH mechanism is used, the expansion cable is used as follows.

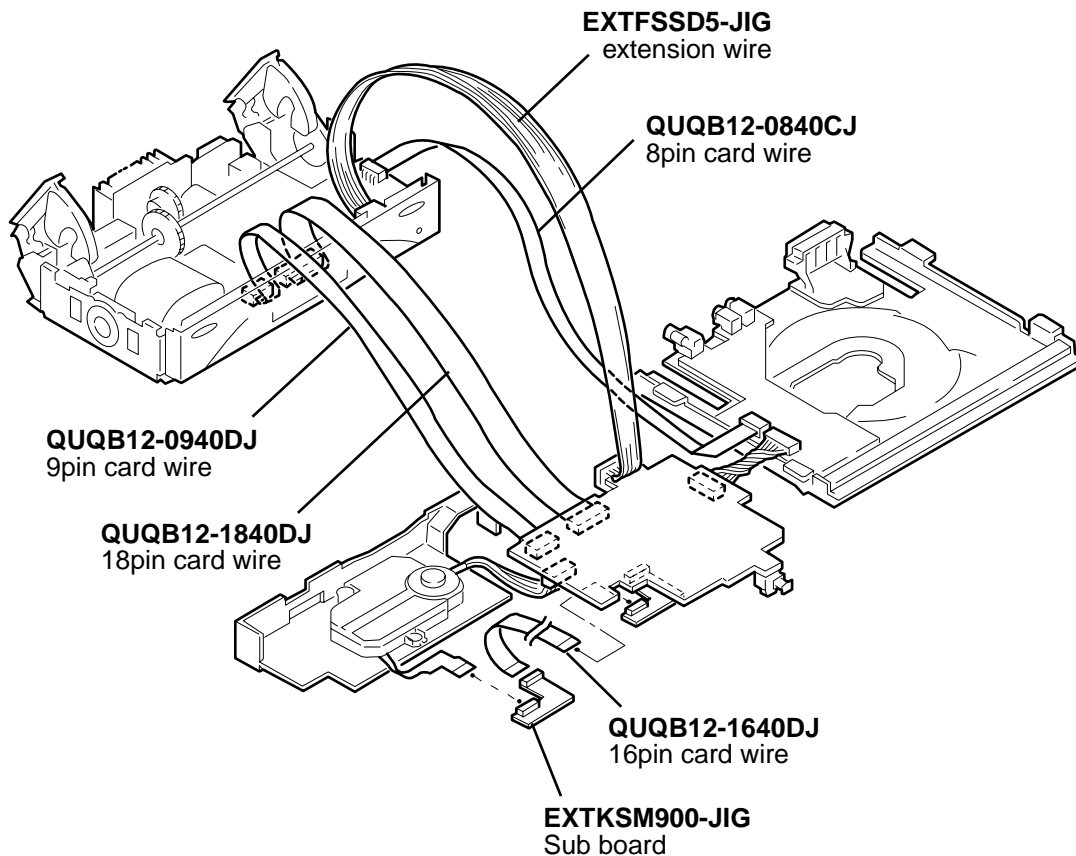

Description of major ICs

■ UPD780024AGKB19 (IC701) : CPU

1. Pin layout

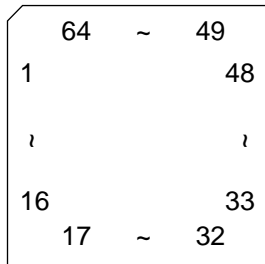

2. Block diagram

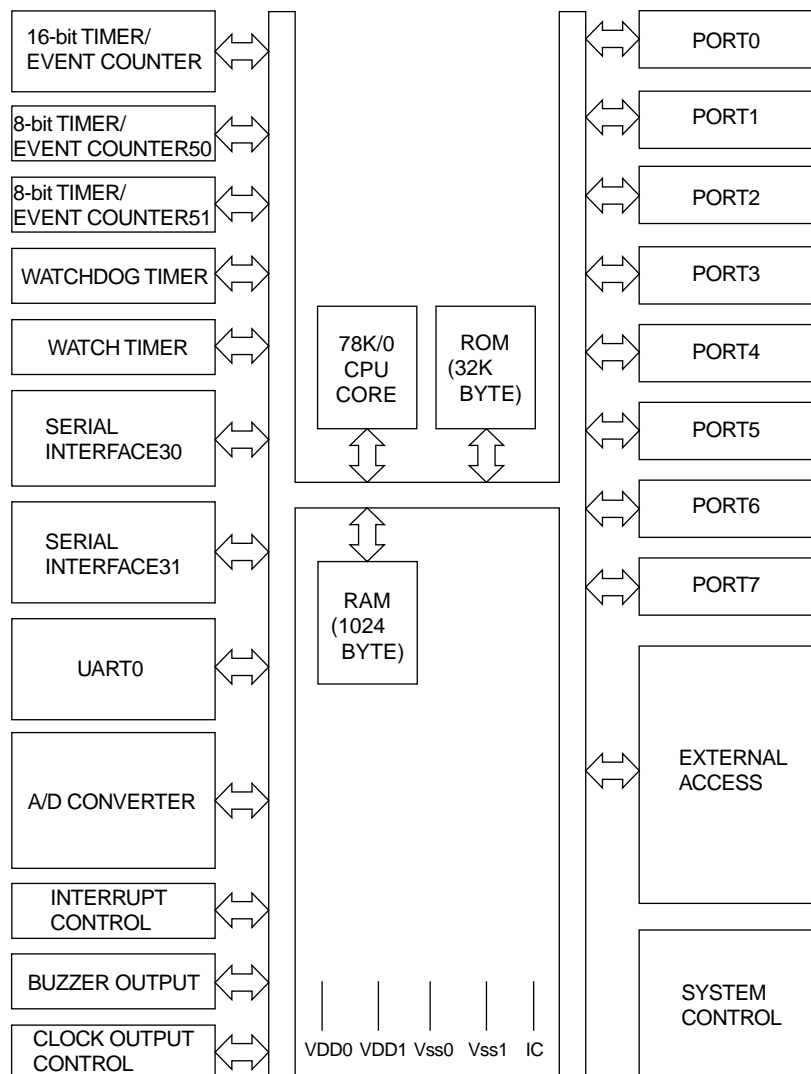

3. Pin function

UPD780024AGKB19

Pin No.	Symbol	I/O	Function
1	MT0	O	CD door motor control signal 0 output
2	MT1	O	CD door motor control signal 1 output
3	MTS	O	Motor speed control output (L:Normal, H:Slow)
4	BLCTL	O	Back light power supply control output
5	AHB	O	AHB ON/OFF control signal output (L:ON, H:OFF)
6	SMUTE	O	System mute control signal output
7	TUST	O	Tuner control strove output
8	CDLED	O	CD LED control signal output (L:OFF, H:ON)
9	VSS0	-	Ground at port section
10	VDD0	-	Power supply at port section
11	MPX	I	Stereo indicator control signal input (L:Stereo)
12	RSDSI	I	RDS data input
13	DRMUTE	O	Driver mute output
14	SCD	I	Voltage detection for safety of CD
15	TUDATA(I)	I	Tuner control data input
16	TUDATA(O)	O	Tuner control data output
17	TUCK	O	Tuner control clock output
18	SUBQ	I	CD control Q code input
19	XRST	O	CD control reset signal output
20	SQCK	O	CD control Q code clock signal output
21	MLD	O	CD control command load signal output
22	MDATA	O	CD control command data signal output
23	MCLK	O	CD control command clock signal output
24	VDD1	-	Power supply without port section
25	AVSS	-	Ground of A/D converter
26	STAT	I	CD control status signal input
27	REST	I	CD rest switch detection signal input
28	KEY1	I	Main body top section tact switch detection signal input
29	KEY2	I	Main body top section tact switch detection signal input
30	KEY3	I	Main body front section tact switch detection signal input
31	SAFETY	I	Voltage detection for safety
32	LDCK	I	CD door motor lock detection signal input
33	VERSION	I	Version detection
34	AVREF	I	Reference voltage input for A/D converter
35	AVDD	-	Analog power supply for A/D converter
36	RESET	I	System reset signal input
37	XT2	-	Sub clock
38	XT1	I	Sub clock signal input 32.768kHz
39	IC	I	Connect to VSS0 or VSS1
40	X2	-	Main clock
41	X1	I	Main clock signal input 4.19MHz
42	VSS1	-	Ground without port section
43	REM	I	Remote controller signal input
44	RDCK	I	RDS clock signal input
45	XKILL	O	Sub clock OSC control signal output
46	BEAT	O	Main clock shift control signal output
47	BUP	I	Back up detection signal input
48	+BCTL	O	Power supply control at back up operating
49	VDATA	O	BD3861FS (VOL & FUNC IC) control data signal output
50	VCLK	O	BD3861FS (VOL & FUNC IC) control clock signal output
51	DOOR1	I	Cd door position detection switch input
52	DOOR2	I	CD door position detection switch input
53	DOOR3	I	CD door position detection switch input
54	LOMUTE	O	LINE OUT muting control signal output
55	RS	O	LCD driver control resistor select signal output
56	E	O	LCD driver control enable signal output
57	D84	O	LCD driver control data bus signal output
58	D85	O	LCD driver control data bus signal output
59	D86	O	LCD driver control data bus signal output
60	D87	O	LCD driver control data bus signal output
61	DIMMER	O	Back light DIMMER control signal output
62	POUT	O	Power supply control signal output for amp section
63	FTU	O	Power supply control signal output for TUNER function
64	FCD	O	Power supply control signal output for CD function

■ AN22000A (IC601) : RF & Servo amp

1. Pin layout

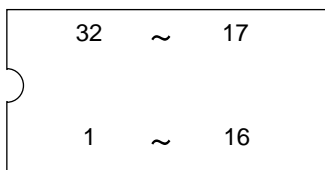

2. Block

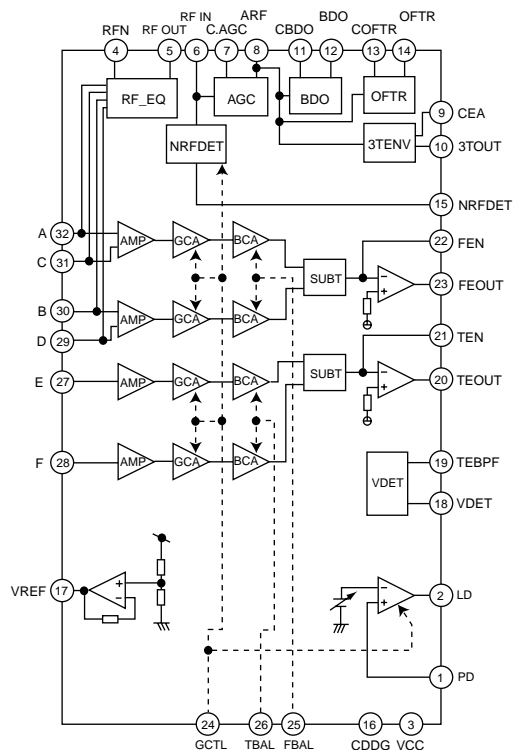

3. Function

Pin No.	Symbol	Function	Pin No.	Symbol	Function
1	PD	APC Amp. Input terminal	16	CDDG	Earth terminal
2	LD	APC Amp. Output terminal	17	VREF	VREF output terminal
3	VCC	Power supply terminal	18	VDET	VDET output terminal
4	RFN	RF addition Amp. Reversing input terminal	19	TEBPF	VDET input terminal
5	RF OUT	RF addition Amp. Output terminal	20	TEOUT	TE Amp. output terminal
6	RF IN	AGC input terminal	21	TEN	TE Amp. reversing input terminal
7	C.AGC	Terminal of connection of capacity of AGC loop filter.	22	FEN	FE Amp. reversing input terminal
8	ARF	AGC output terminal	23	FEOUT	FE Amp. output terminal
9	CEA	Capacity connection terminal for HPF-Amp.	24	GCTL	Terminal GCTL & APC
10	3TOUT	3TENV output terminal	25	FBAL	FBAL control terminal
11	CBDO	Capacity connection terminal for RF shade side envelope detection	26	TBAL	TBAL control terminal
12	BDO	BDO output terminal	27	E	Tracking signal input terminal 1
13	COFTR	Capacity connection terminal for RF discernment side envelope detection	28	F	Tracking signal input terminal 2
14	OFTR	OFTR output terminal	29	D	Focus signal input terminal 4
15	NRFDET	NRFDET output terminal	30	B	Focus signal input terminal 2
			31	C	Focus signal input terminal 3
			32	A	Focus signal input terminal 1

BA15218F-XE (IC102) : Dual operation amplifier

1. Pin layout

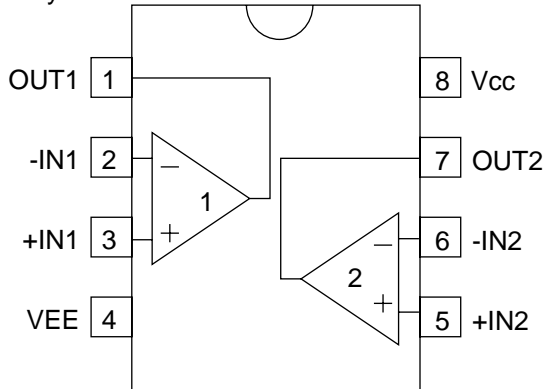

2. Block diagram

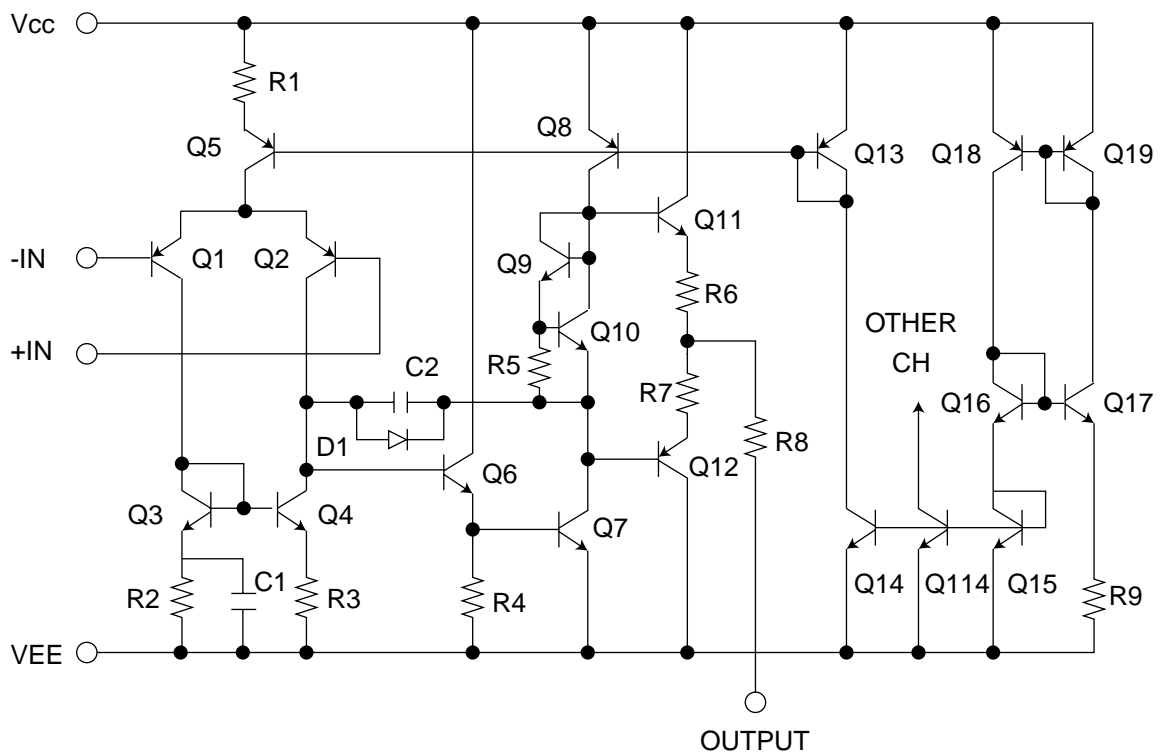

GP1U271X (IC801) : Receiver for remote controller

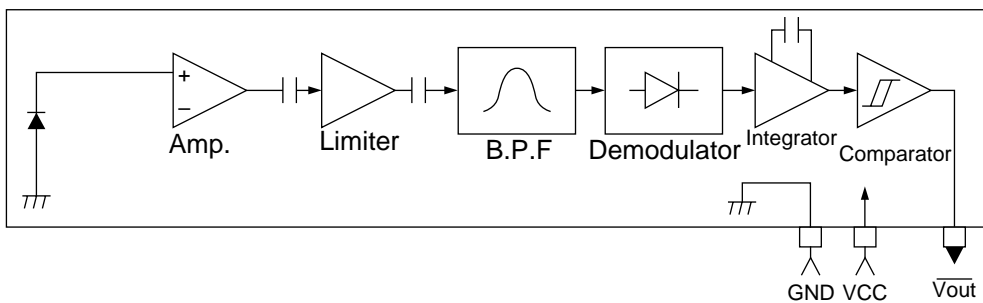

BD3861FS-X (IC501) : Audio sound control

1. Pin layout

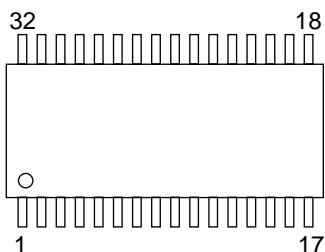

2. Block diagram

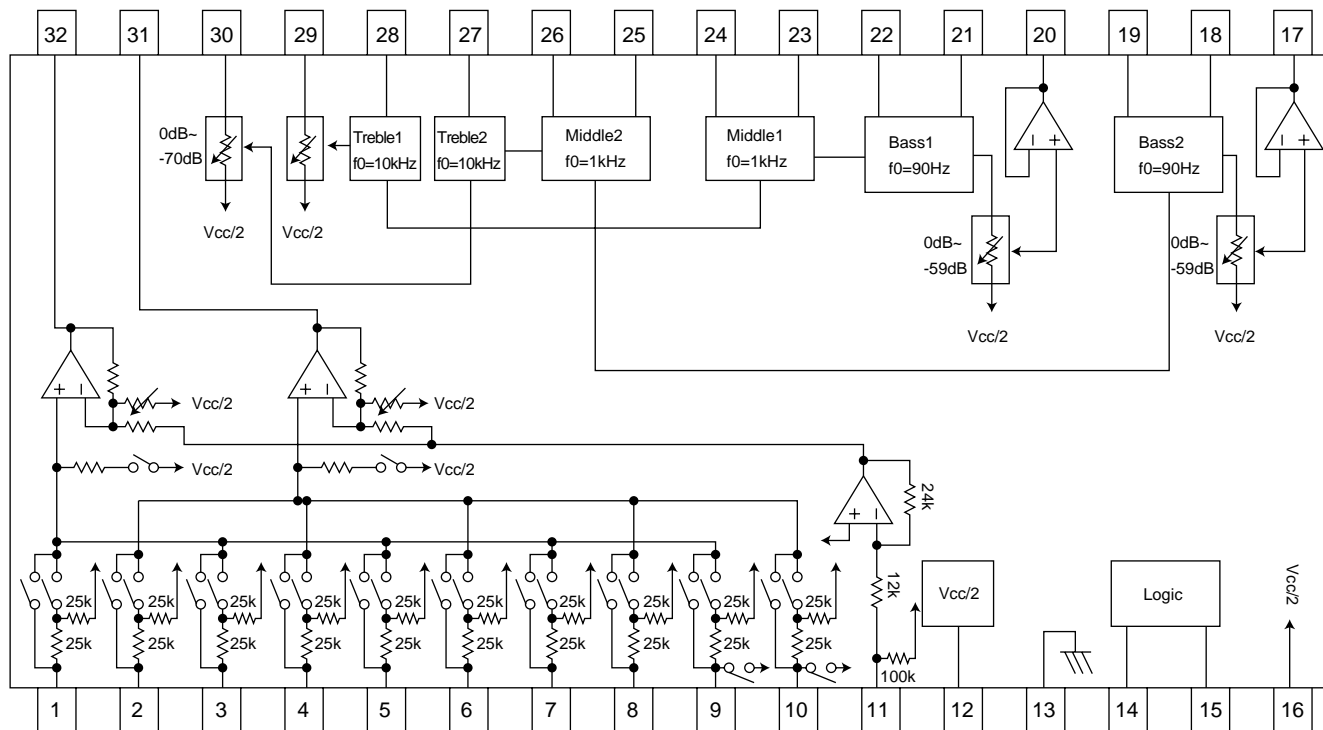

3. Pin function

Pin No.	Symbol	Function	Symbol	Function	
1	A1	CH1 input pin A	17	OUT2	CH2 output pin
2	A2	CH2 input pin A	18	BASS21	CH2 bass filter setting pin
3	B1	CH1 input pin B	19	BASS22	CH2 bass filter setting pin
4	B2	CH2 input pin B	20	OUT1	CH1 output pin
5	C1	CH1 input pin C	21	BASS11	CH1 bass filter setting pin
6	C2	CH2 input pin C	22	BASS12	CH1 bass filter setting pin
7	D1	CH1 input pin D	23	MID11	CH1 middle filter setting pin
8	D2	CH2 input pin D	24	MID12	CH1 middle filter setting pin
9	E1	CH1 input pin E	25	MID21	CH2 middle filter setting pin
10	E2	CH2 input pin E	26	MID22	CH2 middle filter setting pin
11	MIC	Microphone input pin	27	TRE2	CH2 treble filter setting pin
12	FIL	Filter pin	28	TRE1	CH1 treble filter setting pin
13	GND	Ground pin	29	VOL1	CH1 input volume input pin
14	DATA	Serial data latch receiving pin	30	VOL2	CH2 input volume input pin
15	CLK	Serial clock receiving pin	31	GOUT2	CH2 input gain output pin
16	Vcc	Power supply pin	32	GOUT1	CH1 input gain output pin

■ LA4905 (IC301) : 2ch BTL power IC

1. Pinlayput

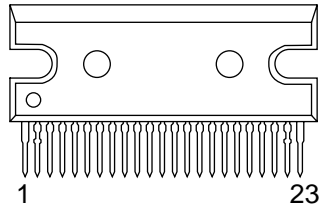

2. Block diagram

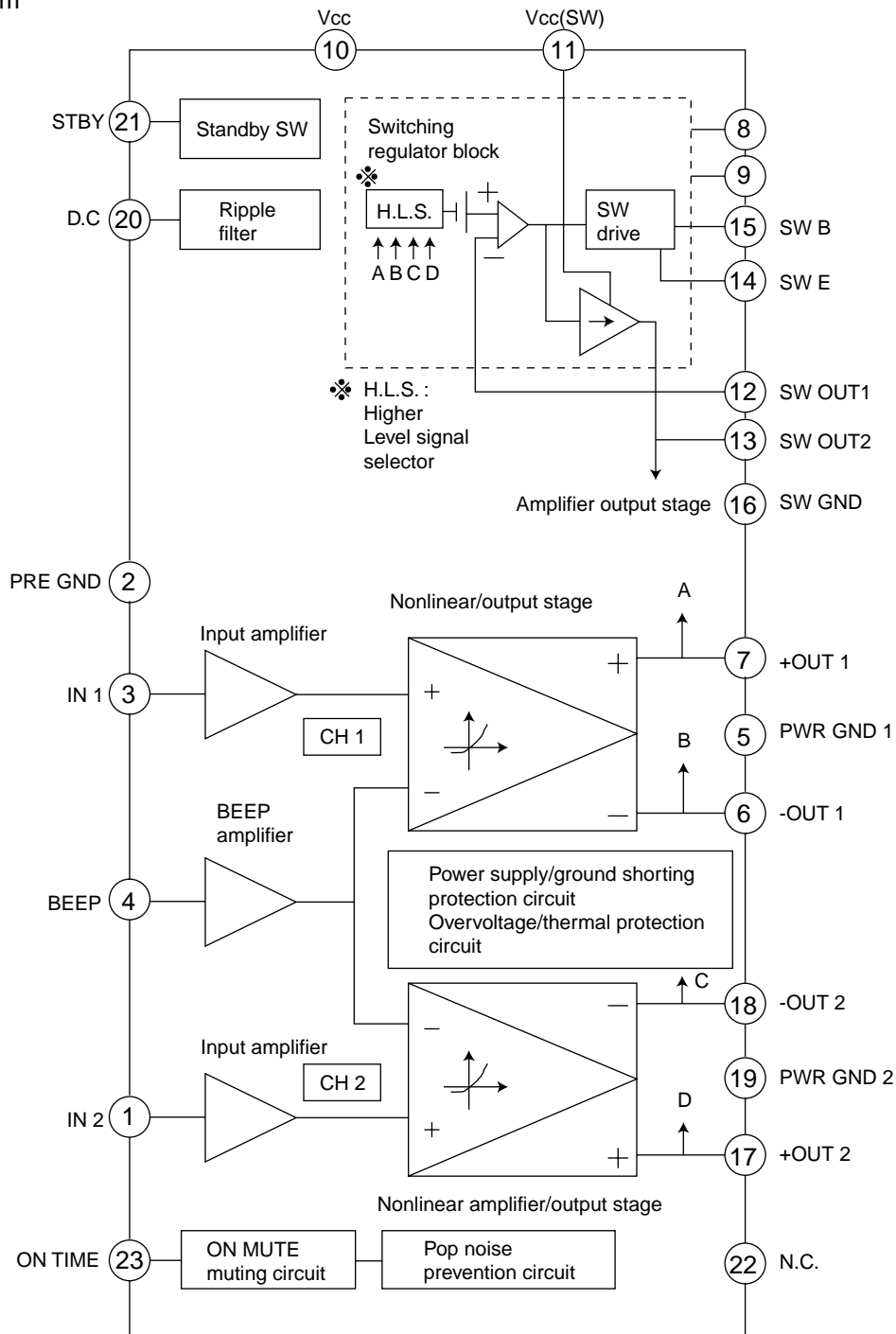

■ LA6541-X (IC601) : Servo driver

1. Pin layout & Block diagram

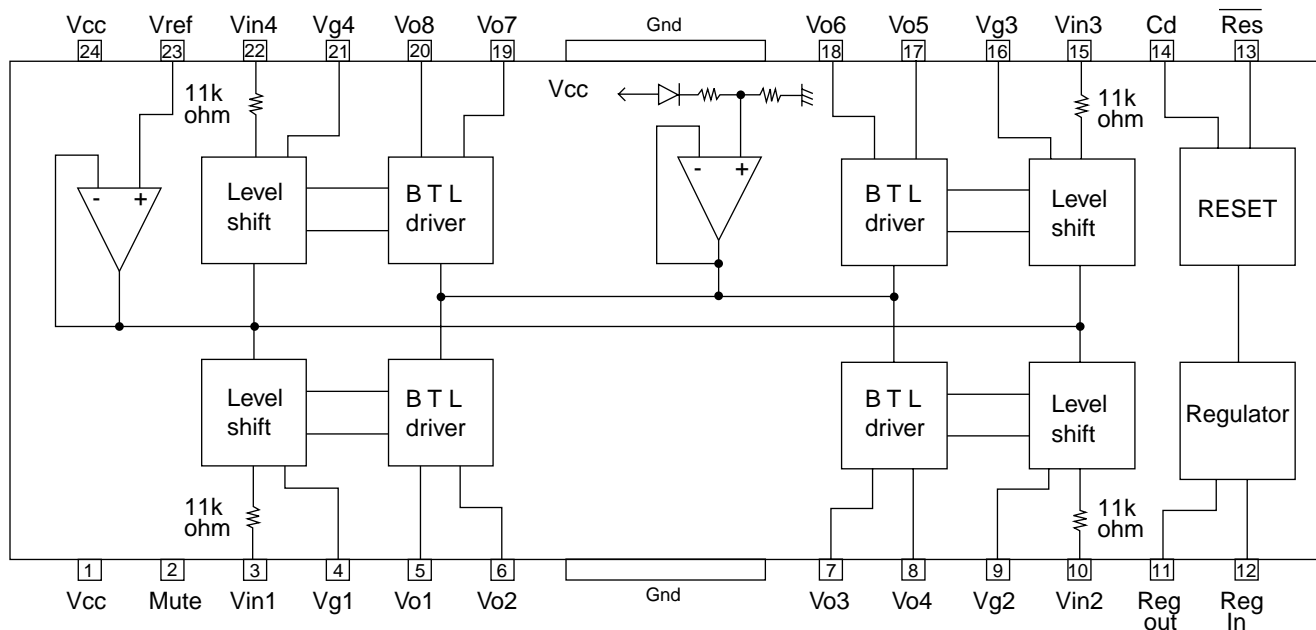

2. Pin function

Pin No.	Symbol	Function
1	Vcc	Power supply (Shorted to pin 24)
2	Mute	All BTL amplifier outputs ON/OFF
3	Vin1	BTL AMP 1 input pin
4	Vg1	BTL AMP 1 input pin (For gain adjustment)
5	Vo1	BTL AMP 1 input pin (Non inverting side)
6	Vo2	BTL AMP 1 input pin (Inverting side)
7	Vo3	BTL AMP 2 input pin (Inverting side)
8	Vo4	BTL AMP 2 input pin (Non inverting side)
9	Vg2	BTL AMP 2 input pin (For gain adjustment)
10	Vin2	BTL AMP 2 input pin
11	Reg Out	External transistor collector (PNP) connection. 5V power supply output
12	Reg In	External transistor (PNP) base connection
13	Res	Reset output
14	Cd	Reset output delay time setting (Capacitor connected externally)
15	Vin3	BTL AMP 3 input pin
16	Vg3	BTL AMP 3 input pin (For gain adjustment)
17	Vo5	BTL AMP 3 output pin (Non inverting side)
18	Vo6	BTL AMP 3 output pin (Inverting side)
19	Vo7	BTL AMP 4 output pin (Inverting side)
20	Vo8	BTL AMP 4 output pin (Non inverting side)
21	Vg4	BTL AMP 4 output pin (For gain adjustment)
22	Vin4	BTL AMP 4 output pin
23	Vref	Level shift circuit's reference voltage application
24	Vcc	Power supply (Shorted to pin 1)

■ LC72136N (IC2) : PLL frequency synthesizer

1. Pin layout

XT	1	22	XT
FM/AM	2	21	GND
CE	3	20	LPFOUT
DI	4	19	LPFIN
CLOCK	5	18	PD
DO	6	17	VCC
FM/ST/VCO	7	16	FMIN
AM/FM	8	15	AMIN
	9	14	
	10	13	IFCONT
SDIN	11	12	IFIN

2. Block diagram

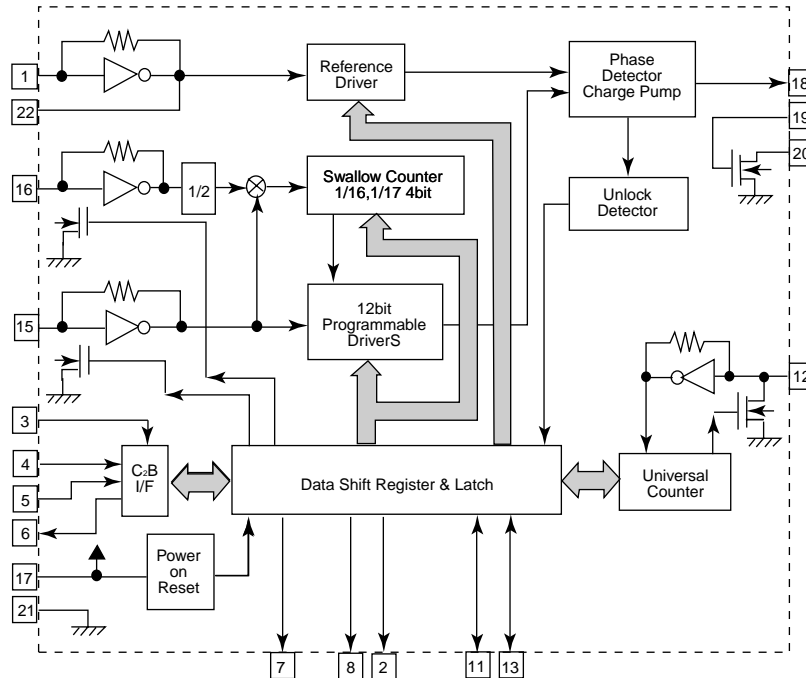

3. Pin function

Pin No.	Symbol	I/O	Function	Pin No.	Symbol	I/O	Function
1	XT	I	X'tal oscillator connect (75kHz)	12	IFIN	I	IF counter signal input
2	FM/AM	O	LOW:FM mode	13	IFCONT	O	IF signal output
3	CE	I	When data output/input for 4pin(input) and 6pin(output): H	14		-	Not use
4	DI	I	Input for receive the serial data from controller	15	AMIN	I	AM Local OSC signal output
5	CLOCK	I	Sync signal input use	16	FMIN	I	FM Local OSC signal input
6	DO	O	Data output for Controller Output port	17	VCC	-	Power suply(VDD=4.5-5.5V) When power ON:Reset circuit move
7	FM/ST/VCO	O	"Low": MW mode	18	PD	O	PLL charge pump output(H: Local OSC frequency Height than Reference frequency. L: Low Agreement: Height impedance)
8	AM/FM	O	Open state after the power on reset	19	LPFIN	I	Input for active lowpassfilter of PLL
9	LW	I/O	Input/output port	20	LPFOUT	O	Output for active lowpassfilter of PLL
10	MW	I/O	Input/output port	21	GND	-	Connected to GND
11	SDIN	I/O	Data input/output	22	XT	I	X'tal oscillator(75KHz)

■ MN662748RPMFA (IC603) : Digital servo & Digital signal processor

1. Pin layout

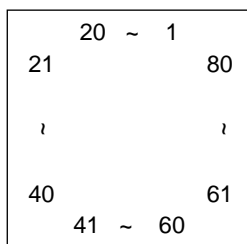

2. Pin functions

Pin No.	Symbol	I/O	Function	Pin No.	Symbol	I/O	Function
1	BCLK	O	Not used	41	TES	O	Tracking error shunt signal output (H:shunt)
2	LRCK	O	Not used	42	PLAY	—	Not used
3	SRDATA	O	Not used	43	WVEL	—	Not used
4	DVDD1	—	Power supply (Digital)	44	ARF	I	RF signal input
5	DVSS1	—	Connected to GND	45	IREF	I	Reference current input pin
6	TX	O	Digital audio interface output	46	DRF	I	Bias pin for DSL
7	MCLK	I	CPU command clock signal input	47	DSLFL	I/O	Loop filter pin for DSL
8	MDATA	I	CPU command data input	48	PLLFL	I/O	Loop filter pin for PLL
9	MLD	I	CPU command load signal input	49	VCOF	—	Not used
10	SENSE	O	Sense signal output	50	AVDD2	—	Power supply (Analog)
11	FLOCK	O	Focus lock signal output Active :Low	51	AVSS2	—	Connected to GND (Analog)
12	TLOCK	O	Tracking lock signal output Active :Low	52	EFM	—	Not used
13	BLKCK	O	sub-code/block/clock signal output	53	PCK	—	Not used
14	SQCK	I	Outside clock for sub-code Q resister input	54	PDO	—	Not used
15	SUBQ	O	Sub-code Q -code output	55	SUBC	—	Not used
16	DMUTE	—	Connected to GND	56	SBCK	—	Not used
17	STATUS	O	Status signal	57	VSS	—	Connected to GND (for X'tal oscillation circuit)
18	RST	I	Reset signal input (L:Reset)	58	X1	I	Input of 16.9344MHz X'tal oscillation circuit
19	SMCK	—	Not used	59	X2	O	Output of X'tal oscillation circuit
20	PMCK	—	Not used	60	VDD	—	Power supply (for X'tal oscillation circuit)
21	TRV	O	Traverse enforced output	61	BYTCK	—	Not used
22	TVD	O	Traverse drive output	62	CLDCK	—	Not used
23	PC	—	Not used	63	FLAG	—	Not used
24	ECM	O	Spindle motor drive signal	64	IPPLAG	—	Not used
25	ECS	O	Spindle motor drive signal	65	FLAG	—	Not used
26	KICK	O	Kick pulse output	66	CLVS	—	Not used
27	TRD	O	Tracking drive output	67	CRC	—	Not used
28	FOD	O	Focus drive output	68	DEMPH	—	Not used
29	VREF	I	Reference voltage input pin for D/A output block (TVD,FOD,FBA,TBAL)	69	RESY	—	Not used
30	FBAL	O	Focus Balance adjust signal output	70	IOSEL	—	pull up
31	TBAL	O	Tracking Balance adjust signal output	71	TEST	—	pull up
32	FE	I	Focus error signal input (Analog input)	72	AVDD1	—	Power supply (Digital)
33	TE	I	Tracking error signal input (Analog input)	73	OUT L	O	Lch audio output
34	RF ENV	I	RF envelope signal input (Analog input)	74	AVSS1	—	Connected to GND
35	VDET	I	Vibration detect signal input (H:detect)	75	OUT R	O	Rch audio output
36	OFT	I	Off track signal input (H:off track)	76	RSEL	—	pull up
37	TRCRS	I	Track cross signal input	77	CSEL	—	Connected to GND
38	RFDET	I	RF detect signal input (L:detect)	78	PSEL	—	Connected to GND
39	BDO	I	BDO input pin (L:detect)	79	MSEL	—	Connected to GND
40	LDON	O	Laser ON signal output (H:on)	80	SSEL	—	Pull up

■ STK411-210E (IC221) : Power amplifier

1. Block diagram

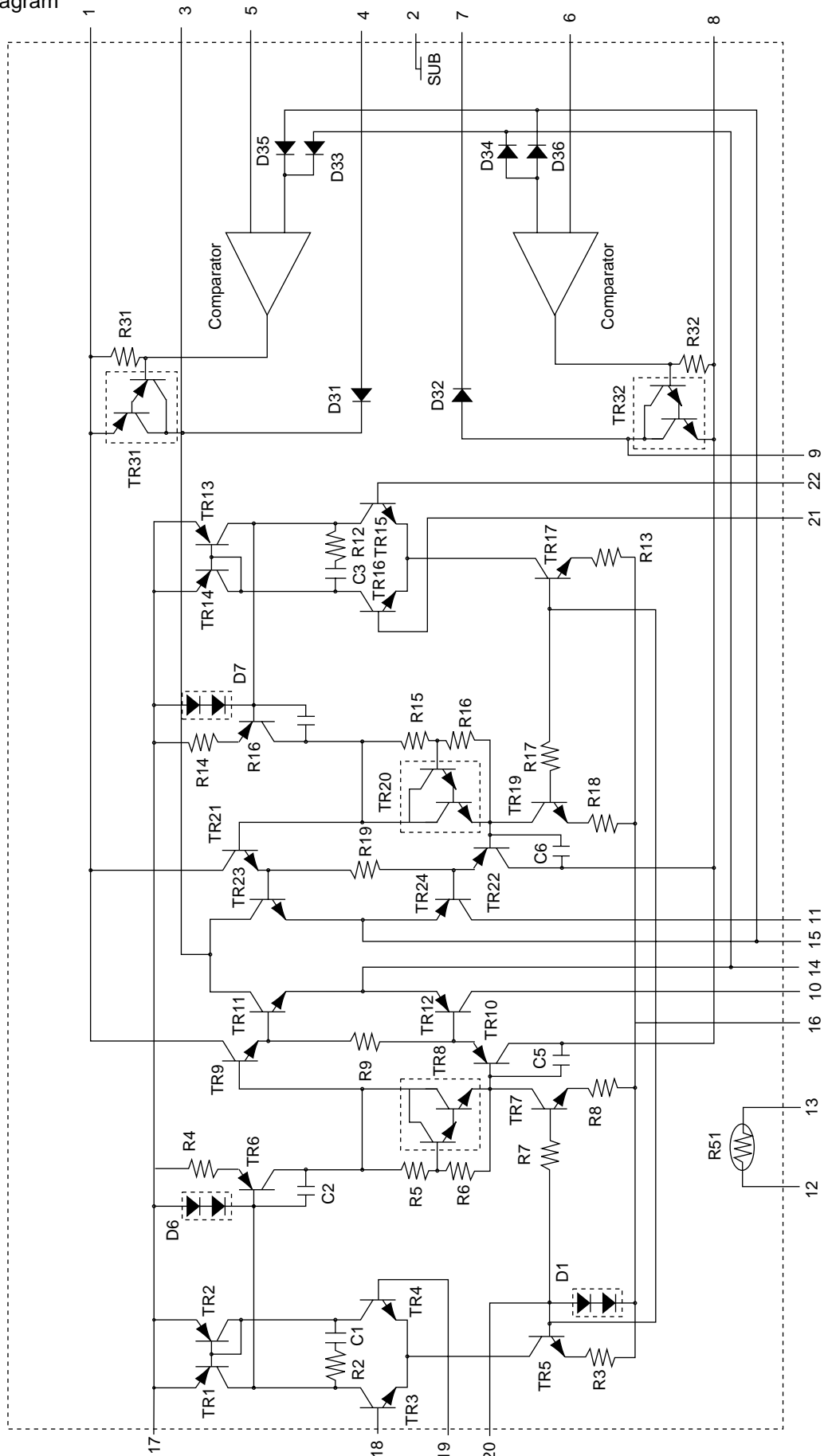

■ TA2057N (IC1) : FM / AM IF amp & Detector

1. Block diagrams

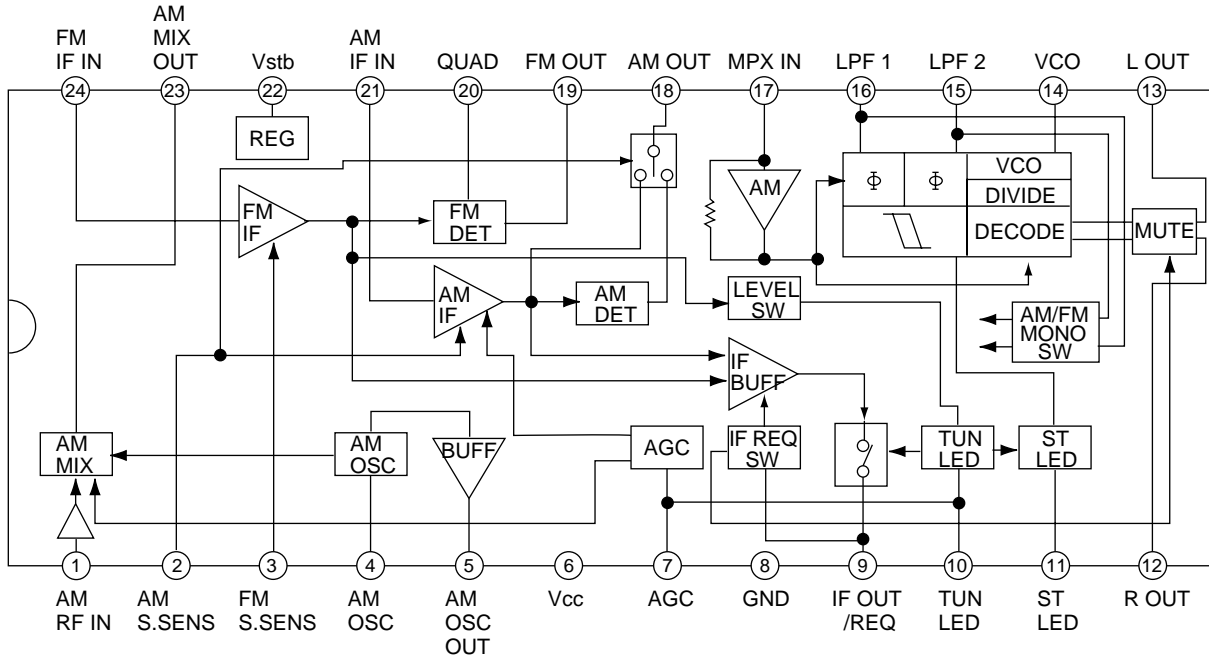

2. Pin function

Pin No.	I/O	Symbol	Function	Pin No.	I/O	Symbol	Function
1	I	AM RF	AMRF signal input	13	O	Lch OUT	Output Lch
2		AM S.SENS		14	O	VCO	Voltage controlled terminal
3		FM S.SENS		15	O	LPF2	When voltage of terminal is MONO at "H" and ST at "L"
4	-	AM OSC	AM local oscillation circuit	16	O	LPF1	When voltage of terminal is AM at "H" and FM at "L"
5	O	AM OSC OUT	AM local oscillation signal output	17	I	MPX IN	Multi plex signal input
6	-	VCC	Power supply	18	O	AM OUT	AM detection signal output
7	I	AGC	AGC voltage input terminal	19	O	FM OUT	FM detection signal output
8	-	GND	Connect to GND	20	I	FM QUAD	Bypass to FMIF
9	O	IF OUT	IF REQ signal output to IC2	21	I	AM IF IN	Input of AMIF signal
10	O	TU IND	Indicator drive output when tuning	22	-	Vst	Fixed voltage output terminal
11	O	ST IND	Stereo indicator output "H"mono . "L"stereo	23	O	AM MIX OUT	Output terminal for AM mixer
12	O	Rch OUT	Output Rch	24	I	FM IF IN	Input of FMIF signal

■ TA8409F-W (IC108) : Motor driver

1. Block diagram

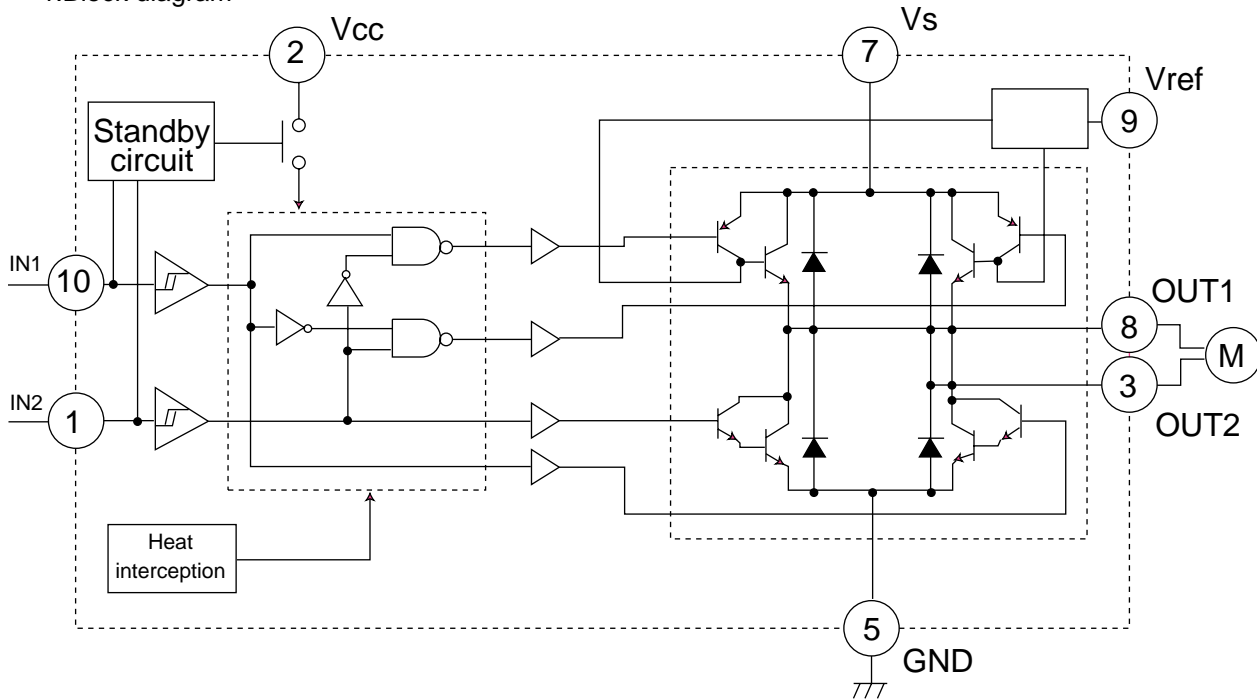

2. Pin function

Input		Output		Mode
IN1	IN2	OUT1	OUT2	MOTOR
0	0	∞	∞	STOP
1	0	H	L	CW/CCW
0	1	L	H	CCW/CW
1	1	L	L	BRAKE

■ NJM4580D-D (IC101,IC211,IC213) : Dual ope amp.

1. Pin layout & Block diagram

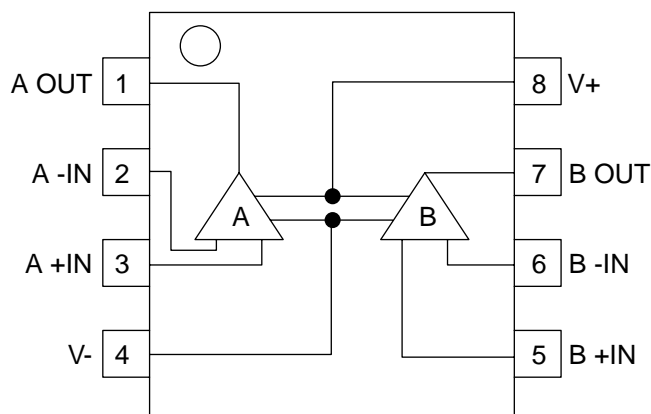

■ KIA78S06P-T (IC702) : Regulator

1. Pin layout

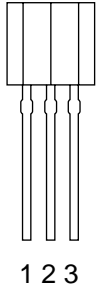

2. Block diagram

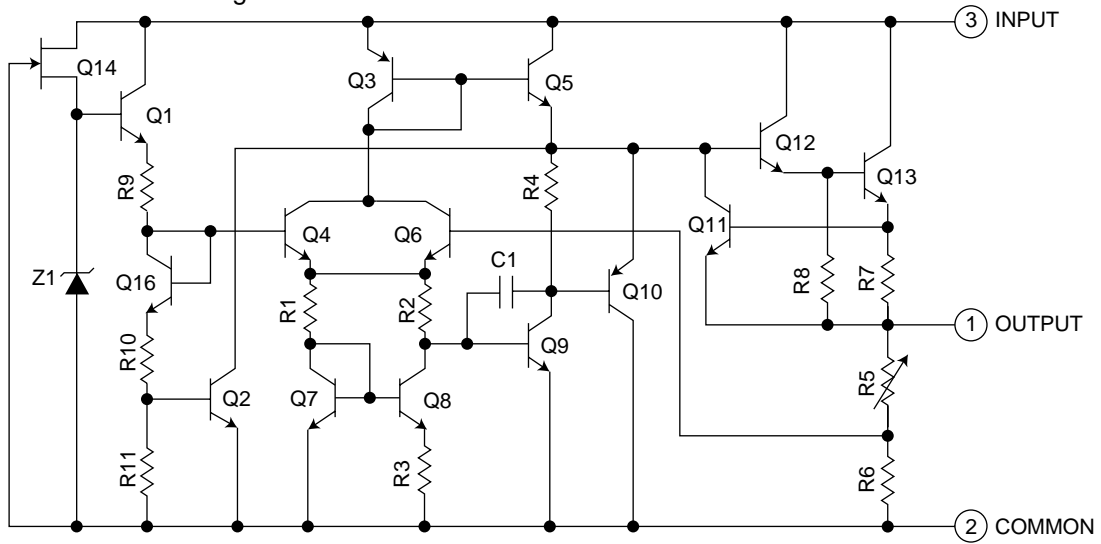

■ TC74HCU04AP (IC251) : 2ch NOR gate

1. Pin layout & Block diagram

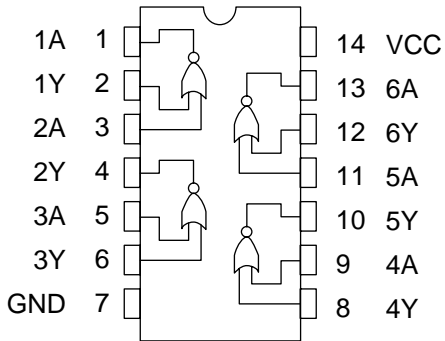

2. True table

A	Y
L	H
H	L

< MEMO >



VICTOR COMPANY OF JAPAN, LIMITED

AUDIO & COMMUNICATION BUSINESS DIVISION

PERSONAL & MOBILE NETWORK BUSINESS UNIT. 10-1,1chome,Ohwatari-machi,Maebashi-city,371-8543,Japan